

# Stair Lift Installation Guide

---

for Synergy and Cardinal  
Straight Stair Lifts

Please read this installation  
guide carefully to ensure  
correct installation of your  
straight stair lift.

  
**AmeriGlide**  
ACCESSIBILITY SOLUTIONS

The information contained within this manual has been designed for use by AmeriGlide approved engineers who have received the appropriate product training in the following categories:

1. Product installation.
2. Testing and commissioning.

It is also assumed that the person using this manual will have the basic knowledge and skills required in both the mechanical and electrical aspects to apply consideration and awareness for the safety of themselves and others involving their work. The contents of this manual are in the recommended order of placement, which forms the full installation, and commissioning of this standard model.

## Table of Contents

Introduction .....	2
Installing Your Straight Stair Lift .....	3
Unboxing and Kit Contents .....	3
Rail Preparation .....	5
Bottom Charge Point Installation .....	12
Rail Installation .....	14
Drive Preparation and Installation .....	16
Leg Preparation and Installation .....	20
Seat Preparation and Installation .....	23
Remote Controls .....	27
Top Charge Point Installation .....	28
Troubleshooting .....	32
Wiring Diagram .....	34
Demonstration and Handover .....	35

# Installing the Straight Stair Lift

## Unboxing and Kit Contents

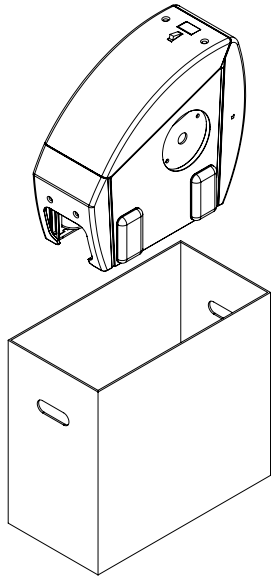

**1x Drive Unit**

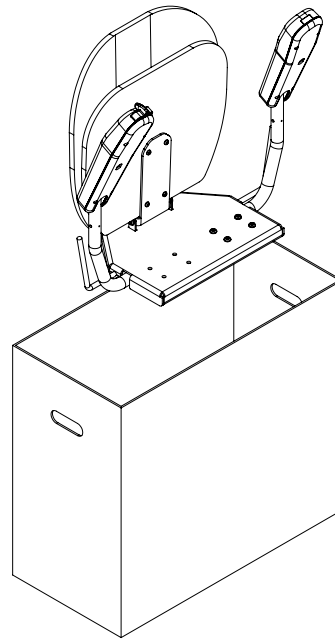

**1x Chair Assembly**

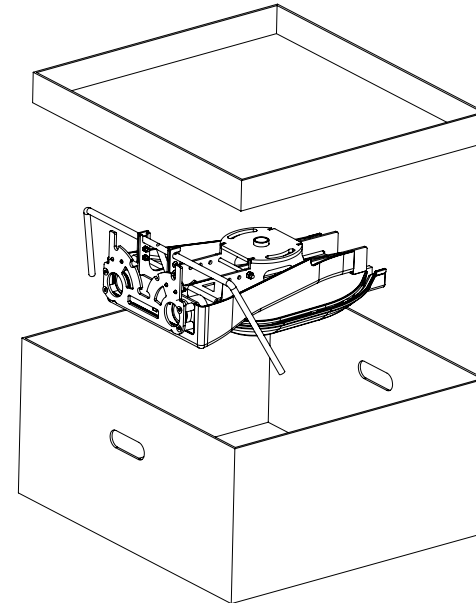

**Seat Leg Assembly & Fitting Kit**

- |                        |                 |
|------------------------|-----------------|
| Batteries 7ah / 9ah HD | Charging points |
| Rail leg supports      | Fixing screws   |
| End covers             | Charger         |

## Kit Box Content

12v Batteries	2
Remotes	2
Holsters	2
AA Batteries	4
Charger	1
Charger Basket	1
Leg Assemblies	5
Charge Ramp Top	1
Charge Ramp Bottom	1
Joint Plate	1
Side Joint Plate Assembly	2
Plastic End Caps	2
2 Core Cable	5m

UK Plug	1
European Plug	1
Leg Screws 6.3 x 50mm	20
Eyelet Connector	4
Barrel Connector	2
Female Spade Connector	2
M10 x 20 Caphead Screw	2
M10 Washer	2
M10 Serrated Washer	2
Grease Tub	1
M4 Nyloc	2
Self-Tapping Screw 8 x 3/4	4

# Rail Preparation

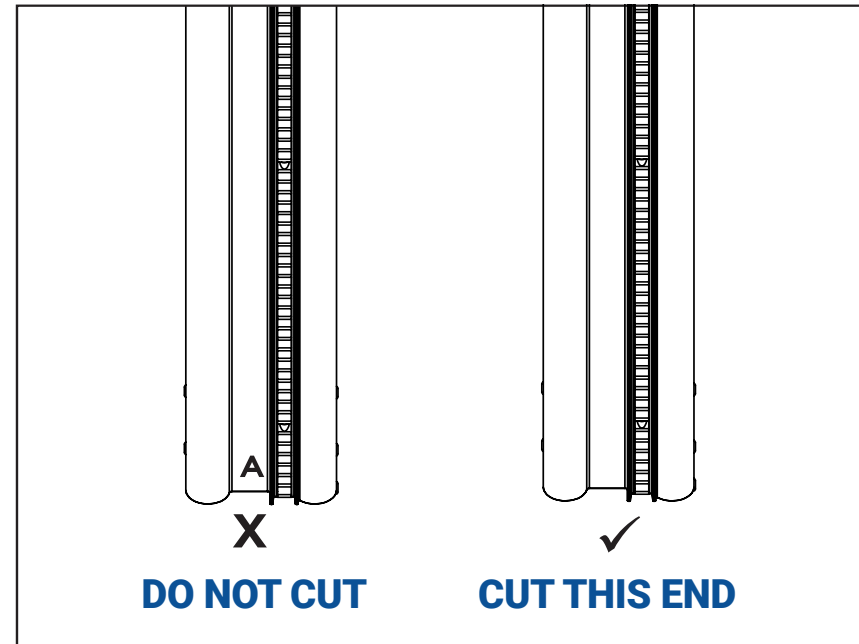
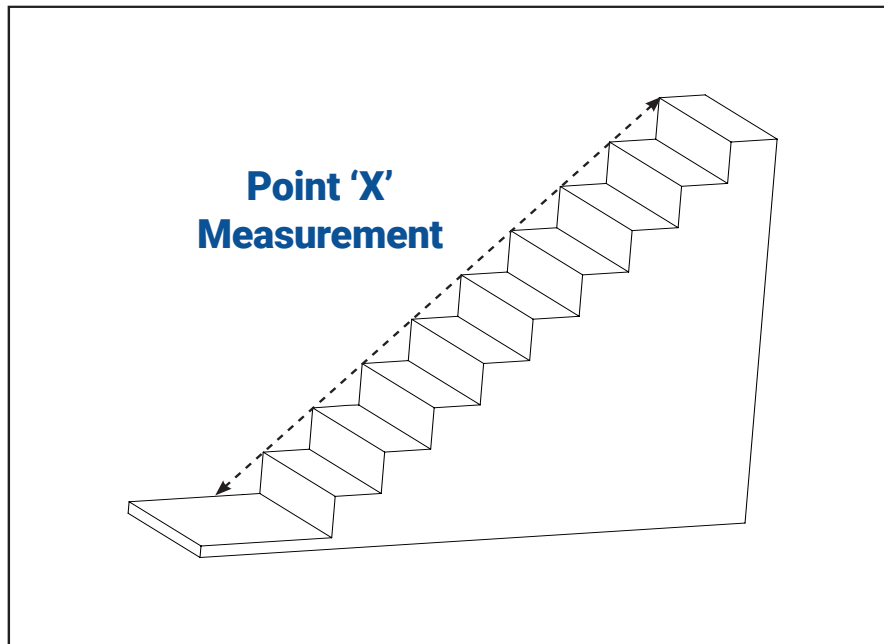

First of all assess the staircase for any problems you may encounter. Secondly you need to measure the point X of the stairs as shown. Then use the table in the following pages to determine the correct cutting length.

The rail has matching numbered stickers at one end, this is the joint end, **always** cut from the other end. Ensure rail cut is square and debarred before installing onto the stairs.

**⚠ WARNING** Ensure there are no more than 2 teeth.

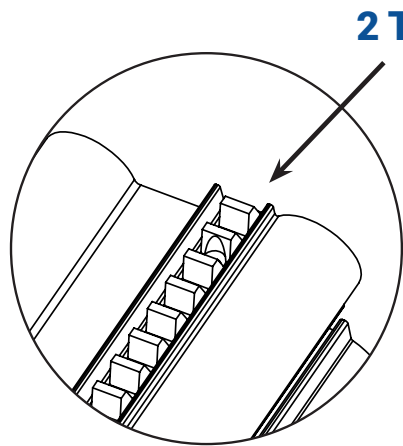

**Warning**

When cutting the top ensure 2 teeth max are after the last rack fixing screw

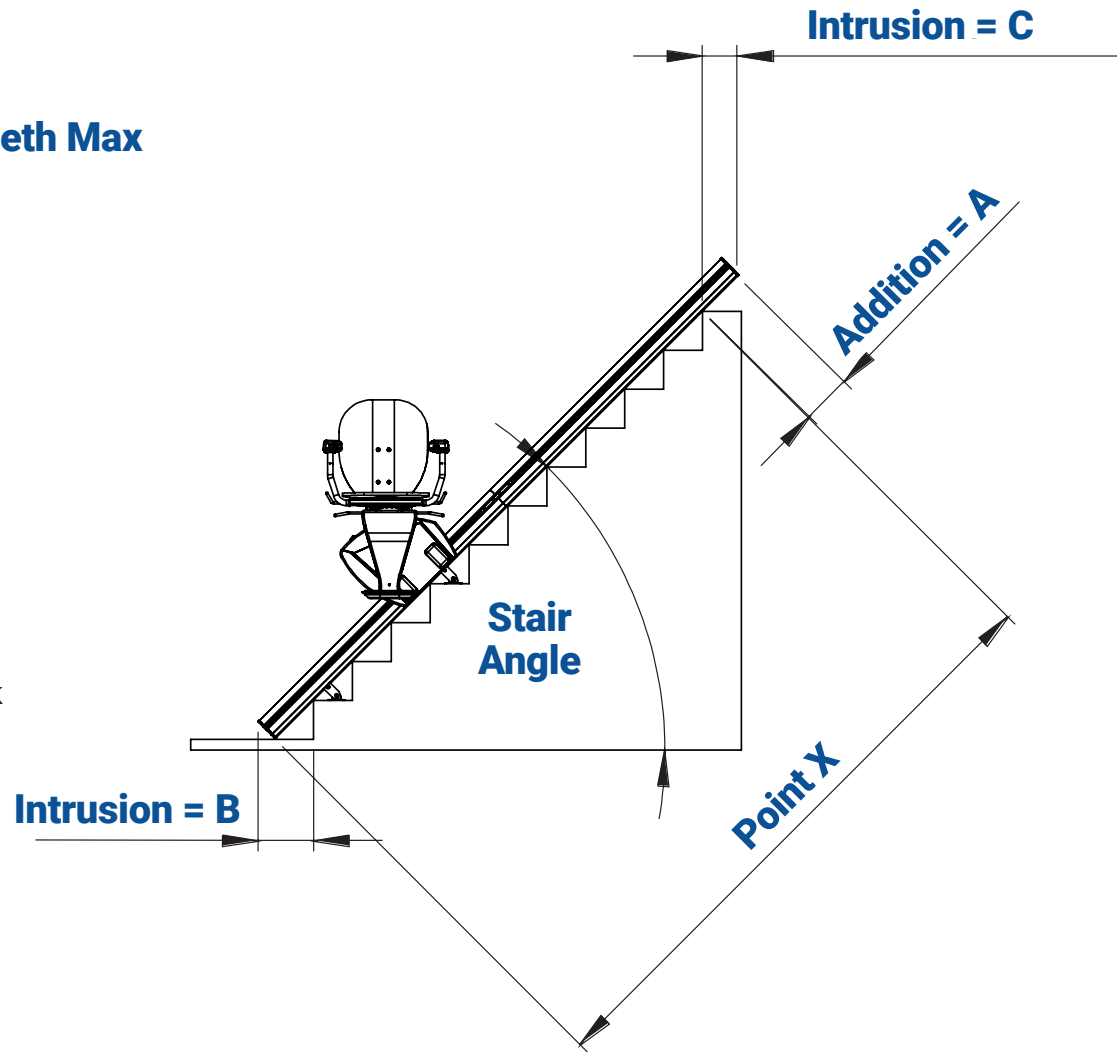

<b>Angle</b>	<b>Addition to Point X for Cutting = A</b>	<b>Intrusion Bottom = B</b>	<b>Intrusion Top = C</b>
--------------	--	-----------------------------	--------------------------

15	128	687	124
16	132	646	126
17	135	610	129
18	138	578	131
19	142	549	133
20	145	523	135
21	148	500	137
22	152	479	139
23	155	460	141
24	158	442	143
25	161	426	145
26	164	411	147
27	167	398	148
28	171	285	150
29	174	373	151
30	177	362	152
31	180	352	154
32	184	342	155
33	187	333	156

<b>Angle</b>	<b>Addition to Point X for Cutting = A</b>	<b>Intrusion Bottom = B</b>	<b>Intrusion Top = C</b>
--------------	--	-----------------------------	--------------------------

34	191	325	156
35	194	316	157
36	197	309	158
37	200	302	159
38	204	295	159
39	207	289	160
40	211	283	160
41	214	277	160
42	218	272	160
43	221	266	160
44	225	261	160
45	229	256	160
46	232	252	160
47	236	247	159
48	240	243	159
49	244	239	159
50	248	235	158
51	253	231	157
52	256	227	156

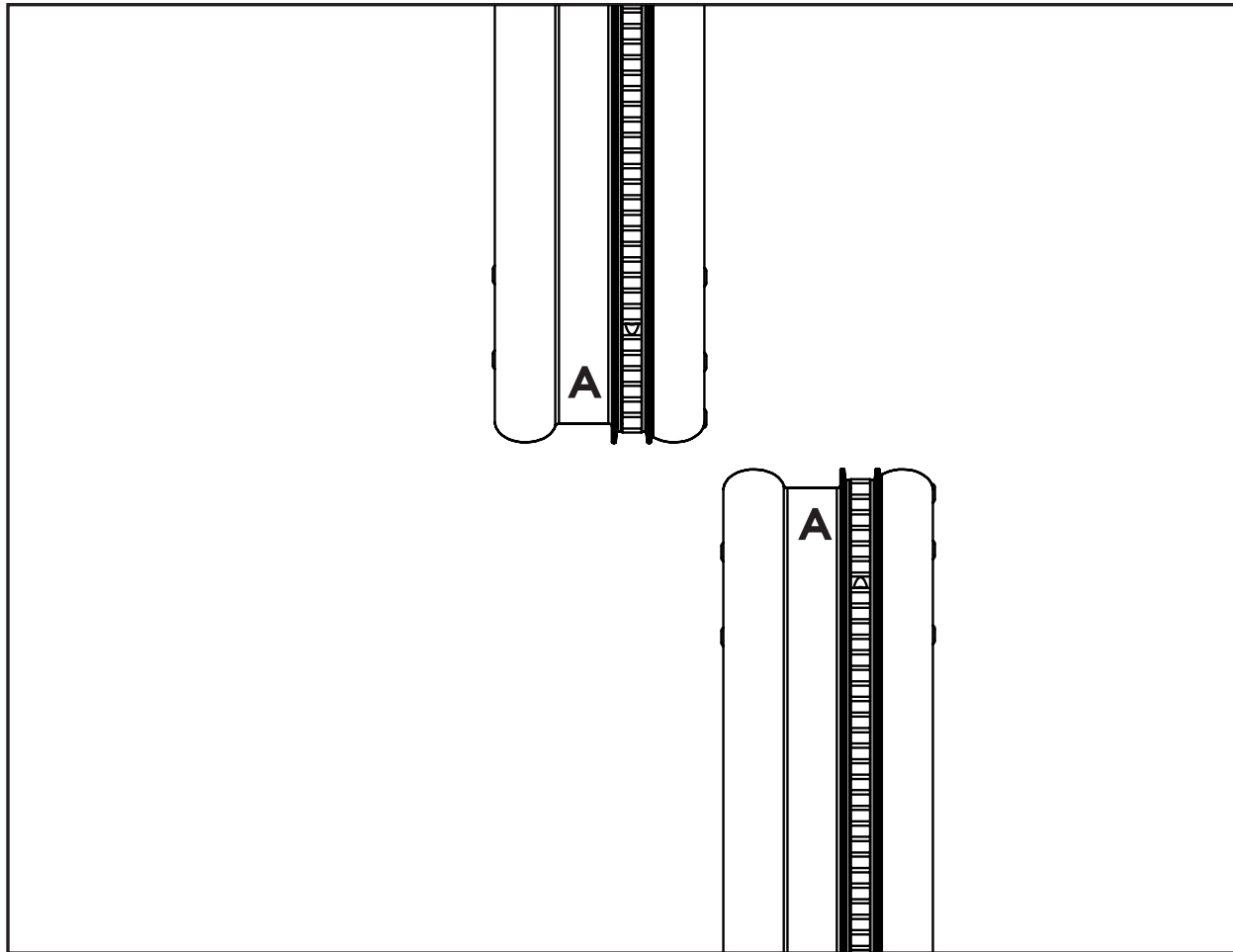

Once cut, the 2 sections of rail are now ready to be jointed. The rails have been carefully cut so the joint perfectly. The ends to be jointed are clearly marked with the matching numbered stickers.

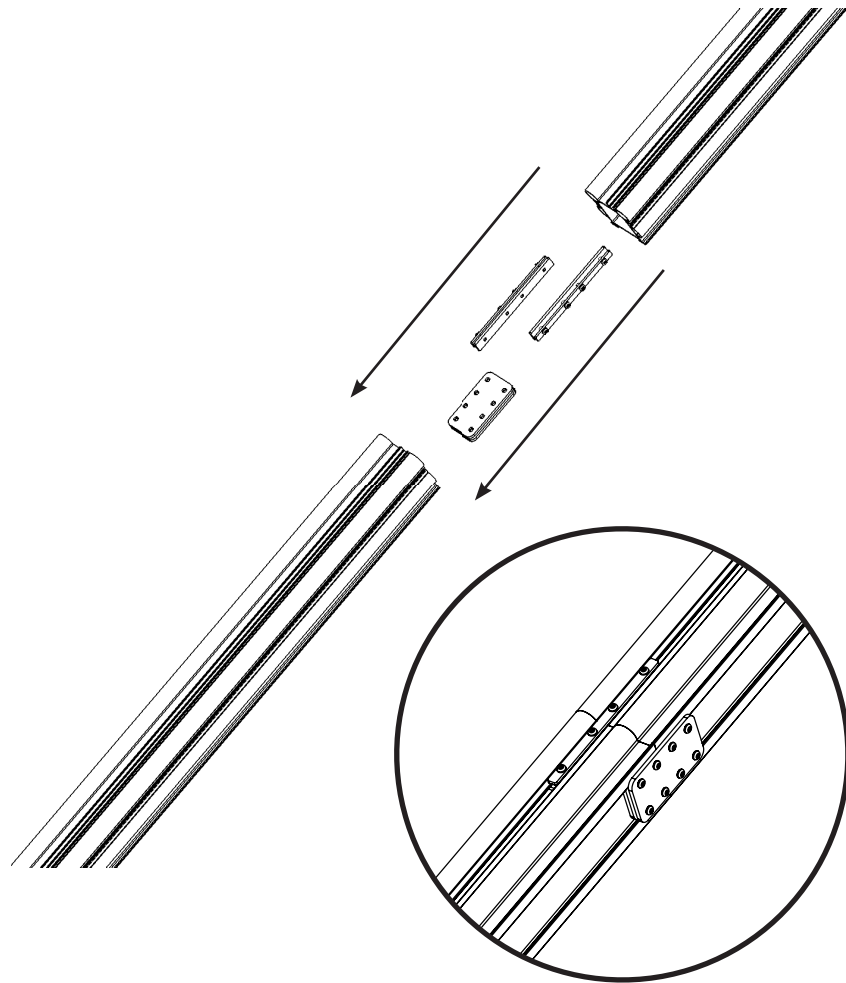

Place the aluminum extrusions on the stairs ready for joining. Locate the 2 side clamp assemblies and the large lower jointing clamp assembly. Slide the clamps into the correct grooves in the rail and tighten, ensuring the clamps are evenly spaced between both rail sections. Then position the rail tight against the wall/stringer.

16

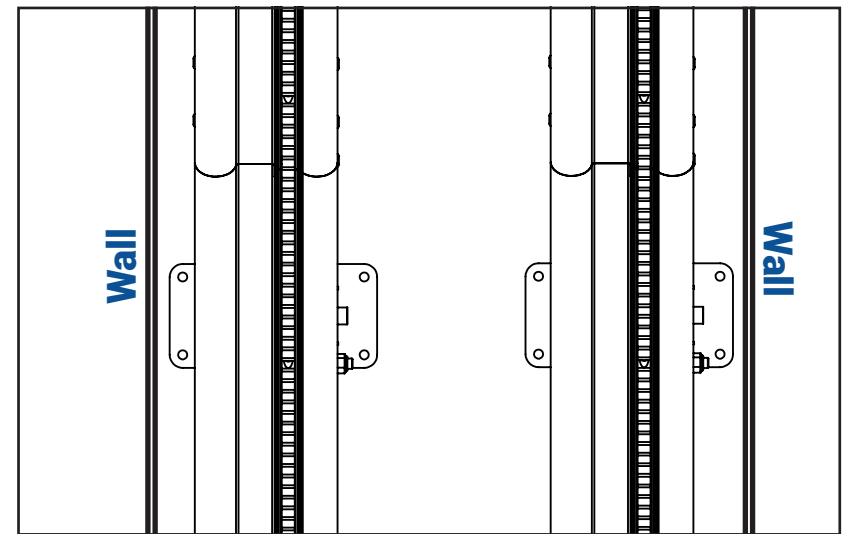

**Left hand  
Rack furthest  
from the wall**

**Right hand  
Rack closest  
to the wall**

To ensure correct handing ensure that the rack is positioned on the correct side for either a left hand or right hand installation.

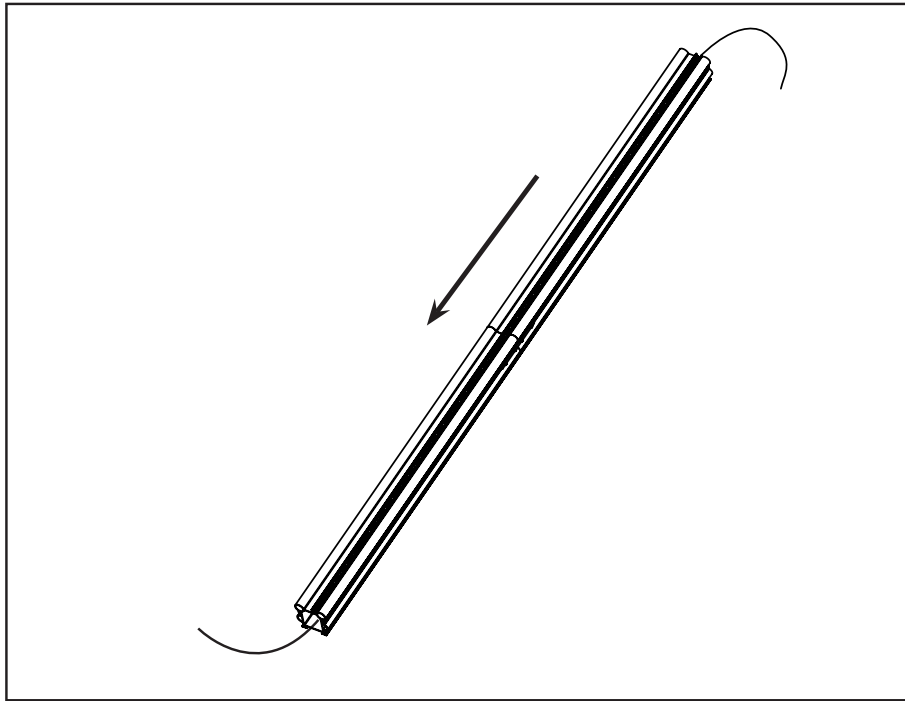

From the top of the track, feed the pre-wired cable through the center section of the rail.

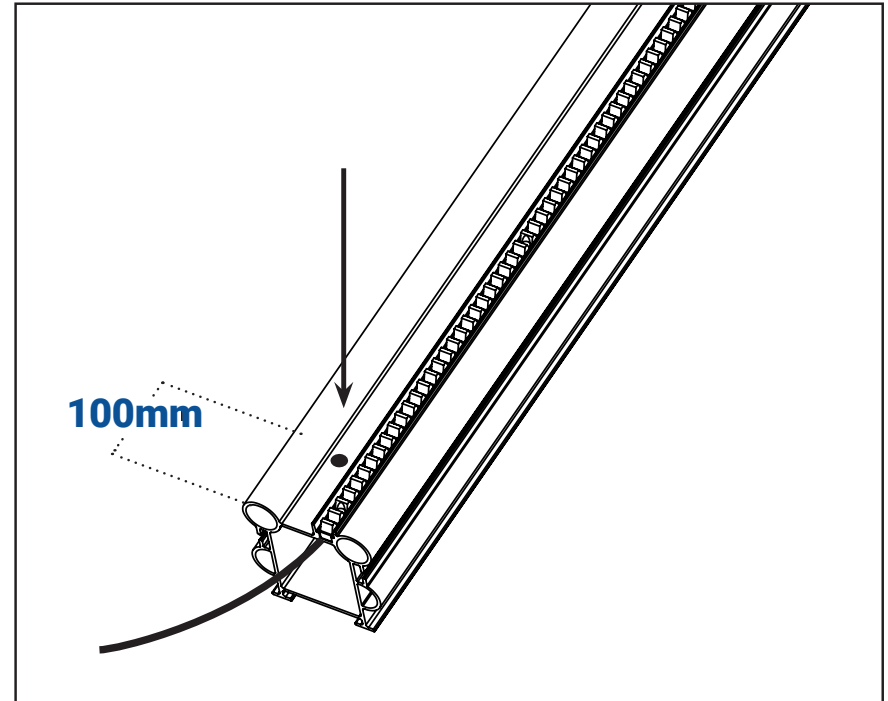

Drill 10mm hole 100mm from the bottom edge of the rail.

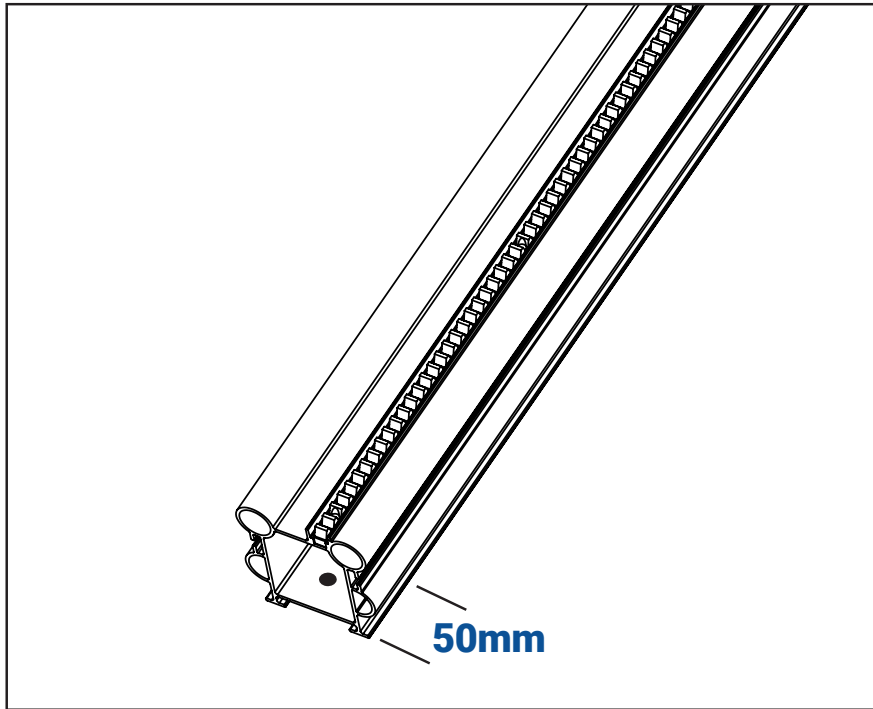

Decide where the charger is to be positioned, either bottom or top. Drill a 10mm hole 50mm from the end of the rail on the **BOTTOM FACE** of the rail.

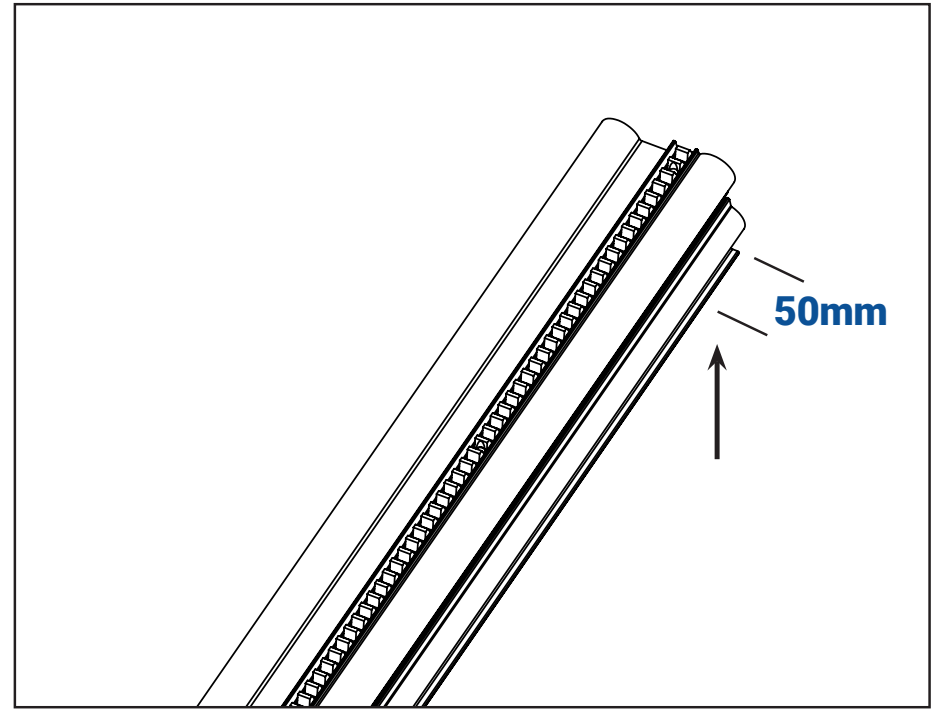

Ensure the hole is debarred to ensure the cable is not damaged when the charger is installed.

# Bottom Charge Point

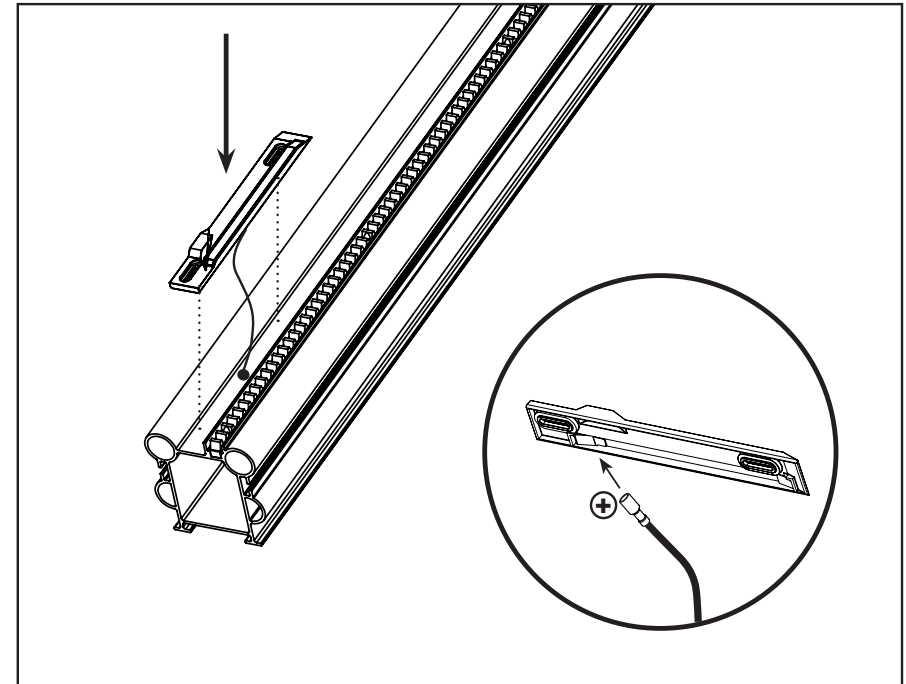
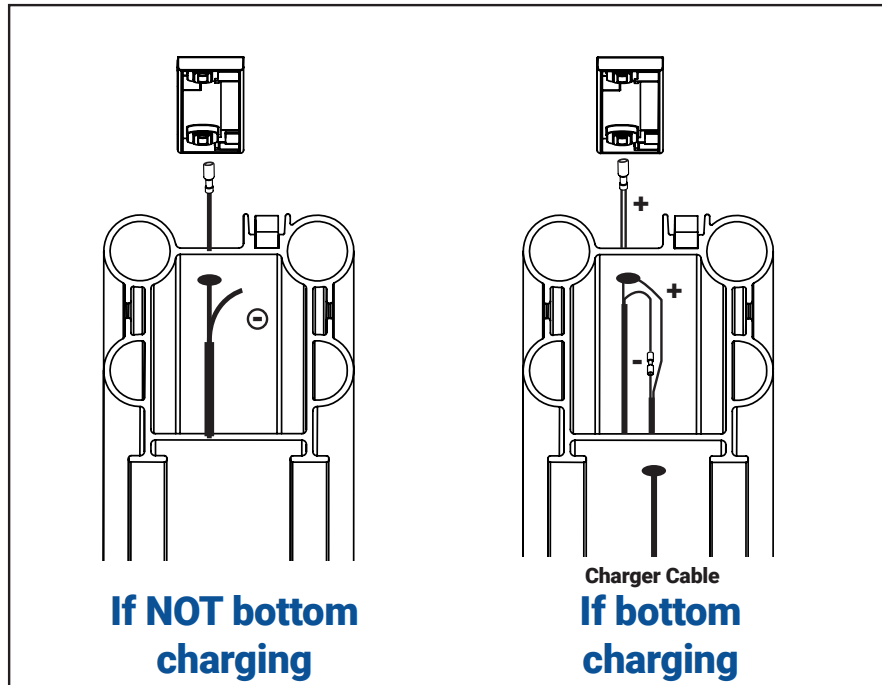

Prepare the cable by attaching one spade connector to the positive side and the negative is unused. Feed the positive spade cable through the hole and connect to the brass charge strip. If connecting the charger at the bottom see diagram above.

Once connected carefully place the charge point against the rail and fix with the provided self tapping screws. If connecting the charger at the bottom see diagram opposite to complete.

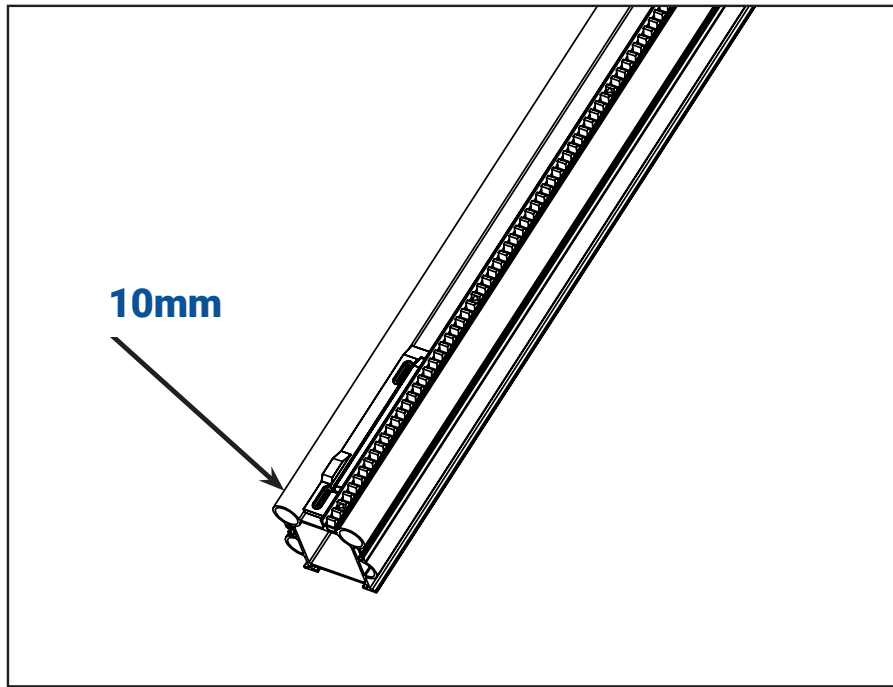

Ensure the charge bracket is fixed 10mm from the edge of the track.

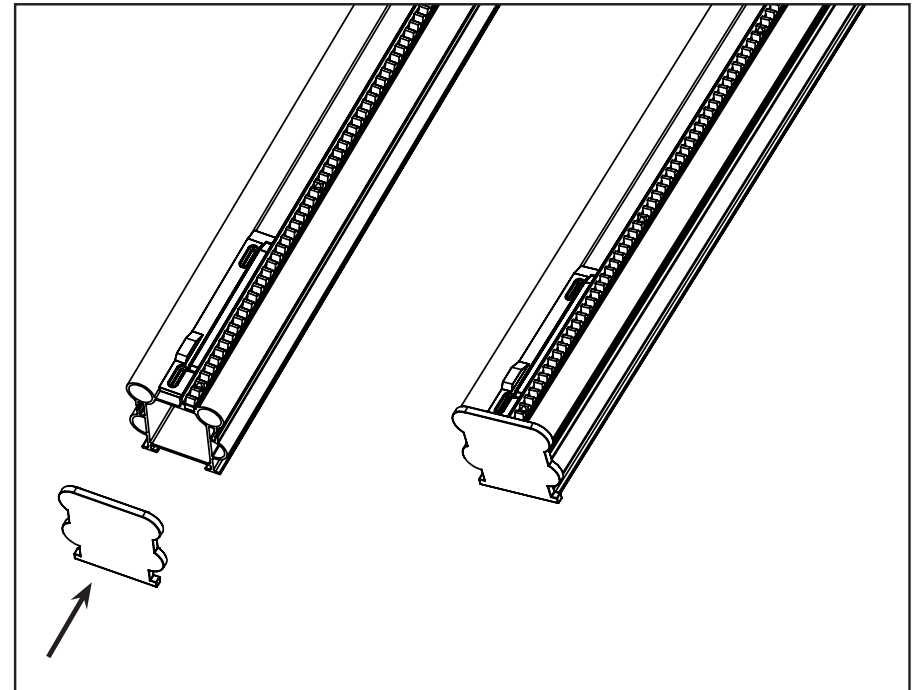

Place the lower cap onto the rail by hand being careful as not to break the plastic.

# Rail Installation

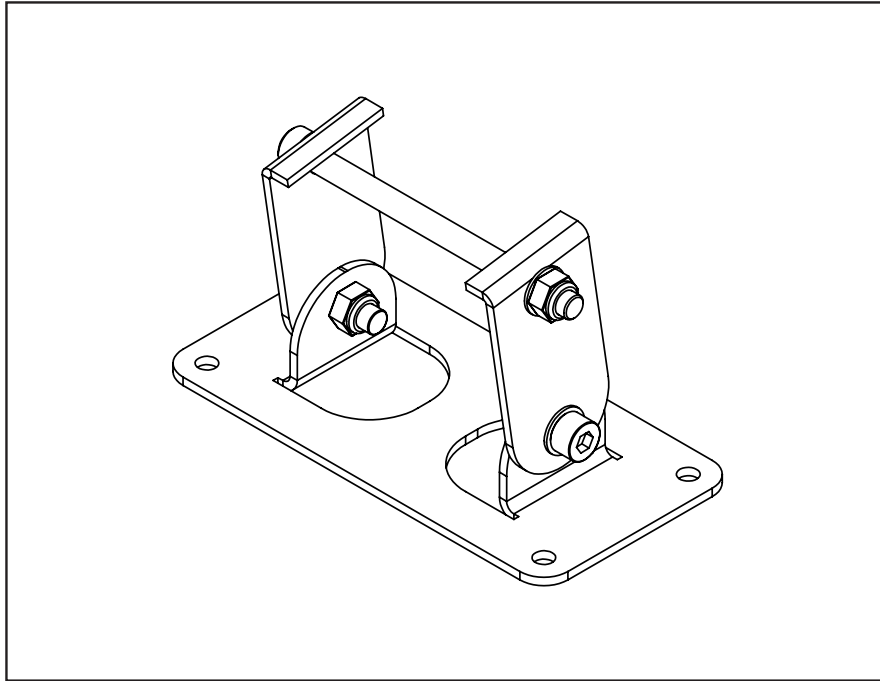

The leg brackets arrive pre-assembled for ease of installation.

To place in position attach the clamps to the rail by sliding the 2 side sections of the clamp over the lower lip of the rail and tighten with your fingers.

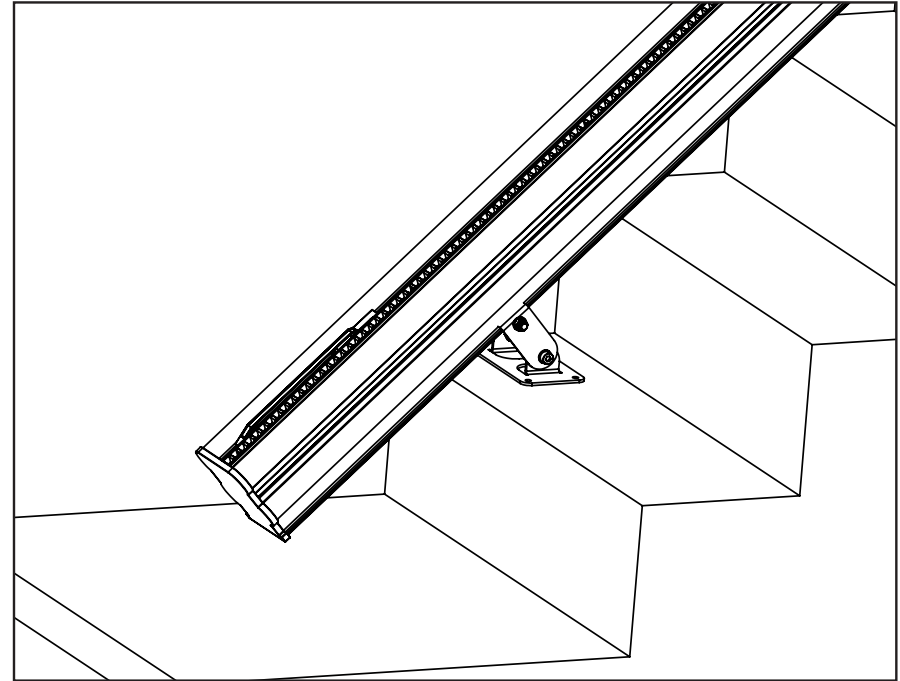

Fix the leg bracket onto the first step and slide the clamp until it sits on the face of the step. The rail should be gently rested onto the nosing of the stairs. When in position tighten the clamp bolts using a torque wrench set to 20Nm as over tightening could crush the aluminum rail

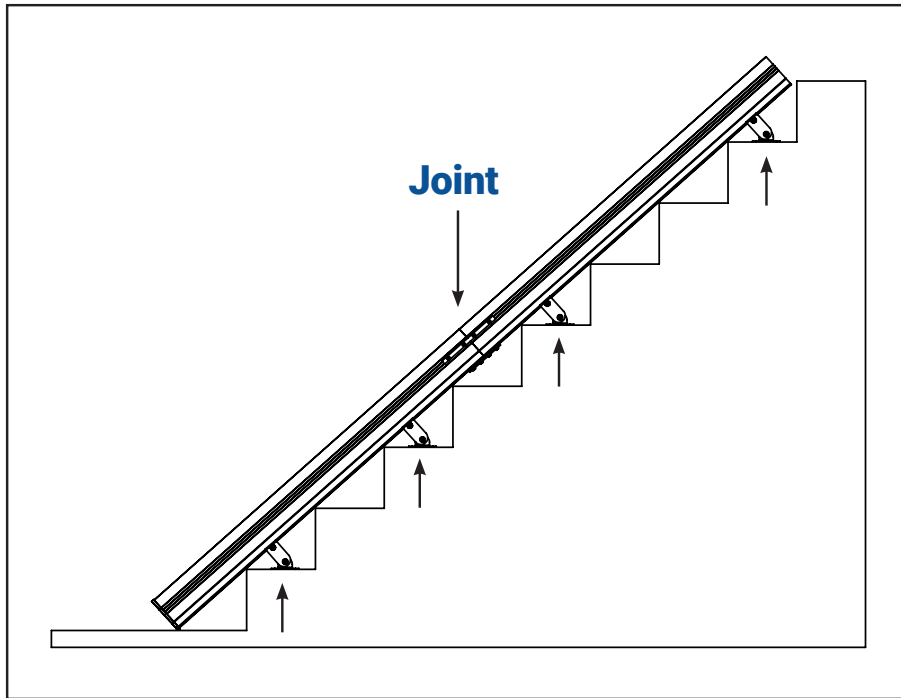

Turn over the rail for access to the underside and slide legs onto the rail. On a standard length installation all 4 / 5 must be fitted. There must be a leg on 1 step, legs no further than 1 step above and below the rail joint and a leg on the step below landing.

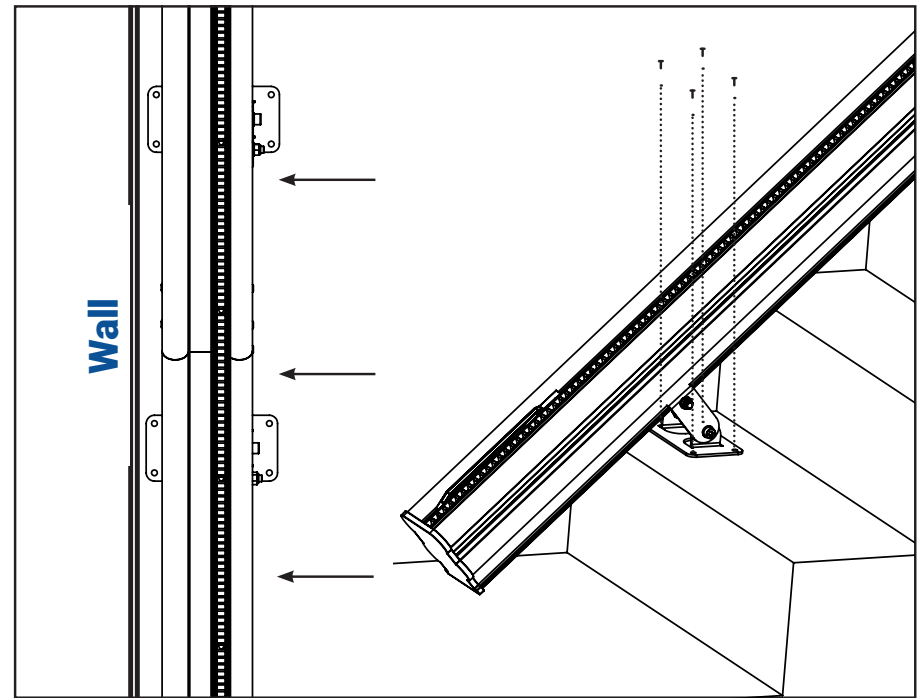

Rail to be set up with a minimum gap of 25mm between the stringer or the wall. Then begin to screw the down and tighten all the leg plate bolts.

## Drive Assembly

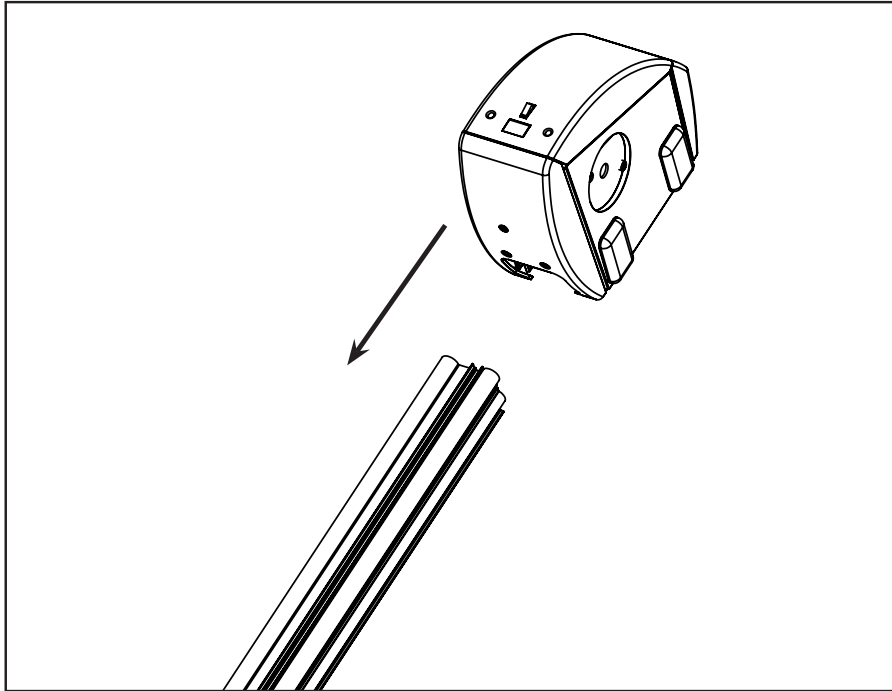

Load carriage from the top of the rail and carefully lower carriage down the rail ensuring the rollers are located correctly onto the rail extrusion and that charging / final limit switches don't get caught on the end of the rail.

Slowly lower the carriage down until the pinion rests against the racking.

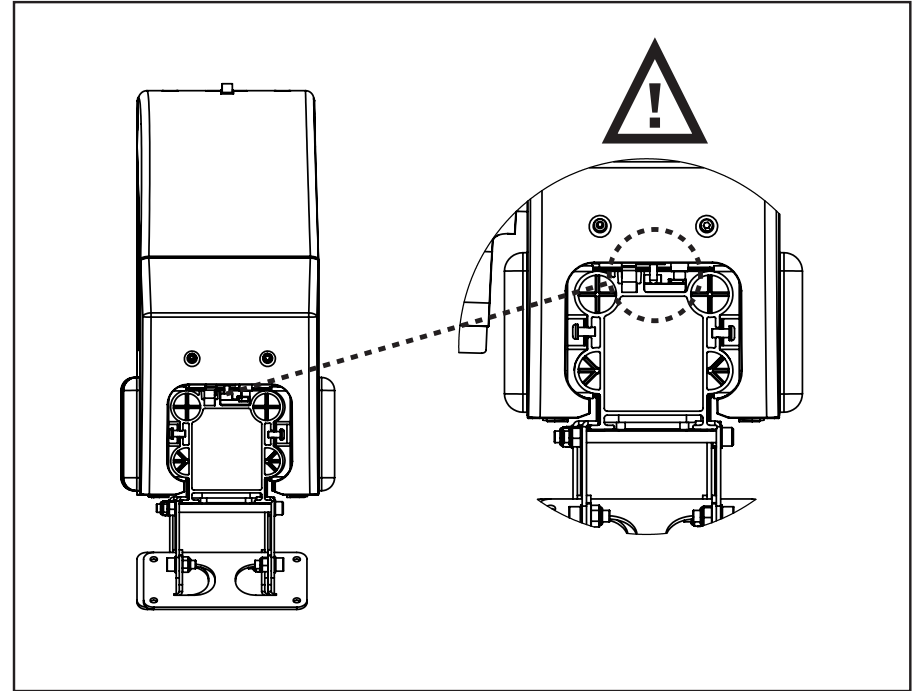

Be cautious when loading not to damage the brass charge pin inside the drive unit.

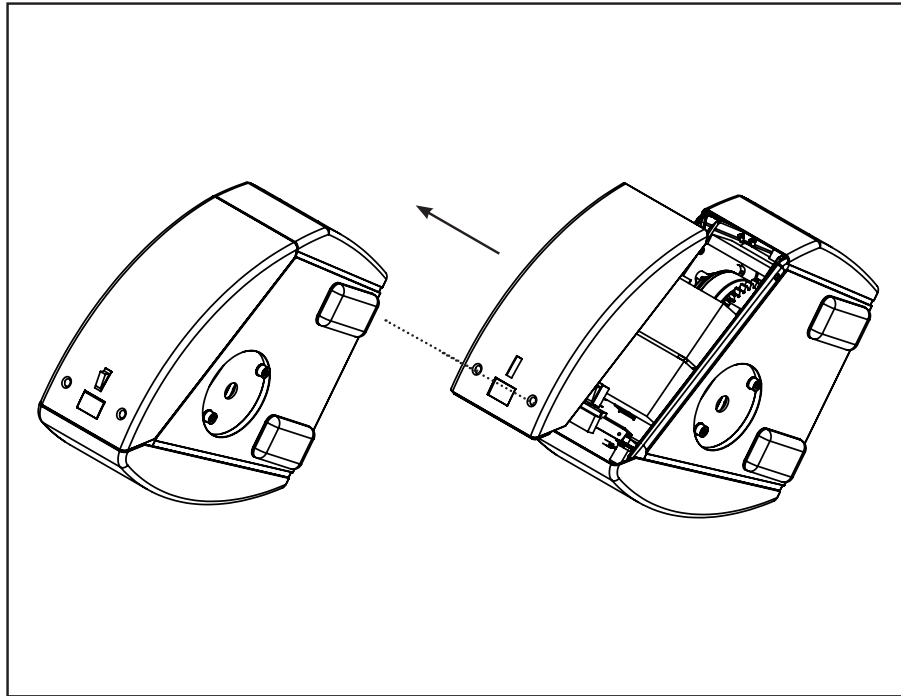

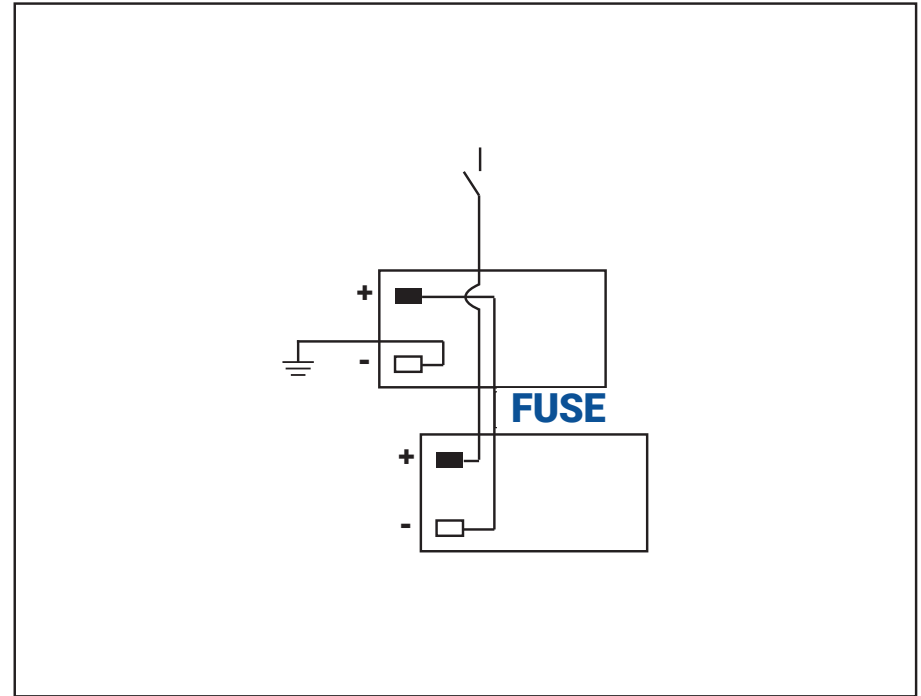

Remove the drive unit main cover by removing the 2 screws as illustrated. Lift the tab at the opposite end to reveal the battery trays.

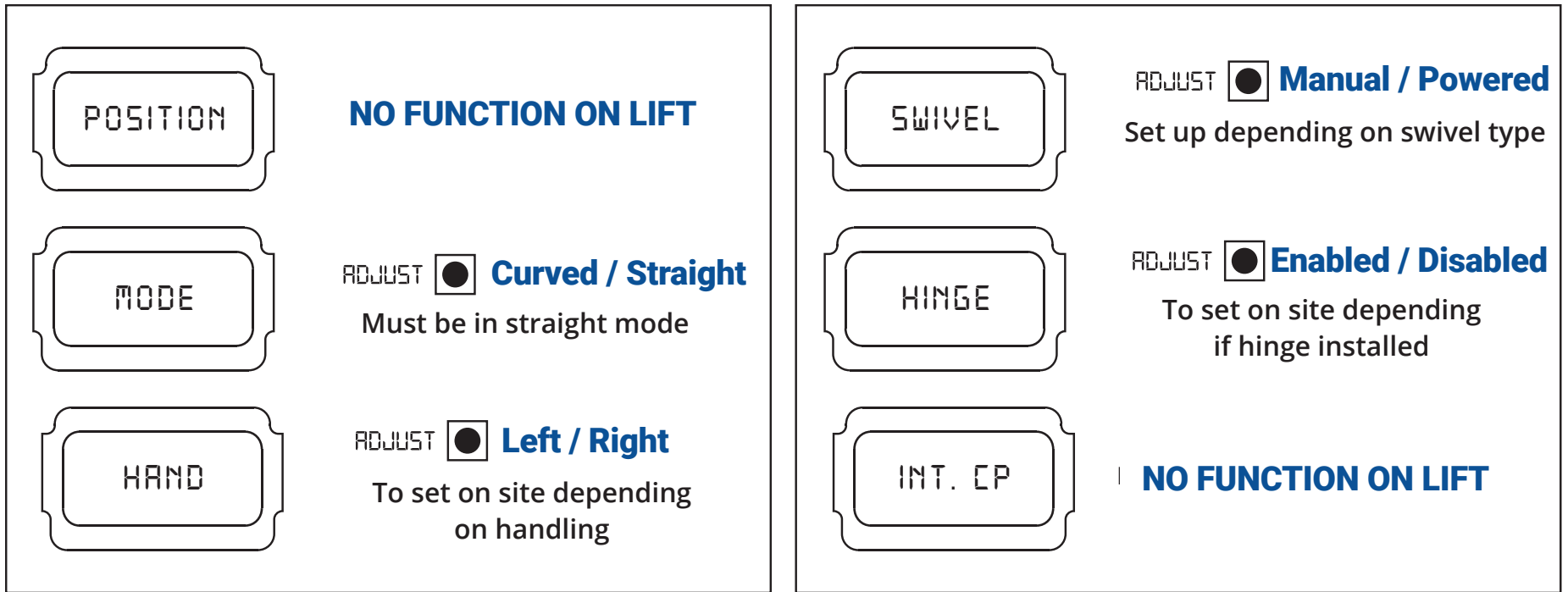

Insert the batteries, connect the wires from the on / off switch and earth and inline fuse holder. As shown above.



To Set up the PCB use the scroll button to cycle through the menu options.

	ADJUST <input type="checkbox"/> <b>Quiet / Alarm</b> Audible beep during travel
	ADJUST <input checked="" type="checkbox"/> <b>Channel 1/2/3/4</b> If multiple lifts in near proximity
	ADJUST <input checked="" type="checkbox"/> <b>Select Language</b> Choose 1 of 7 language options

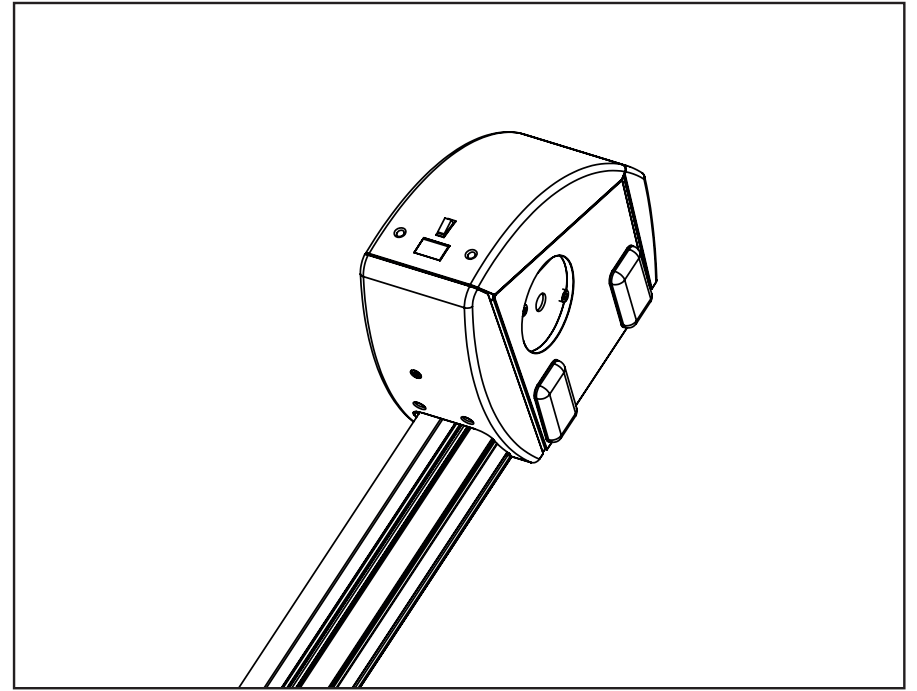

Once the PCB is set up you can now begin assembling the chassis leg and stair lift seat.

## Leg Assembly

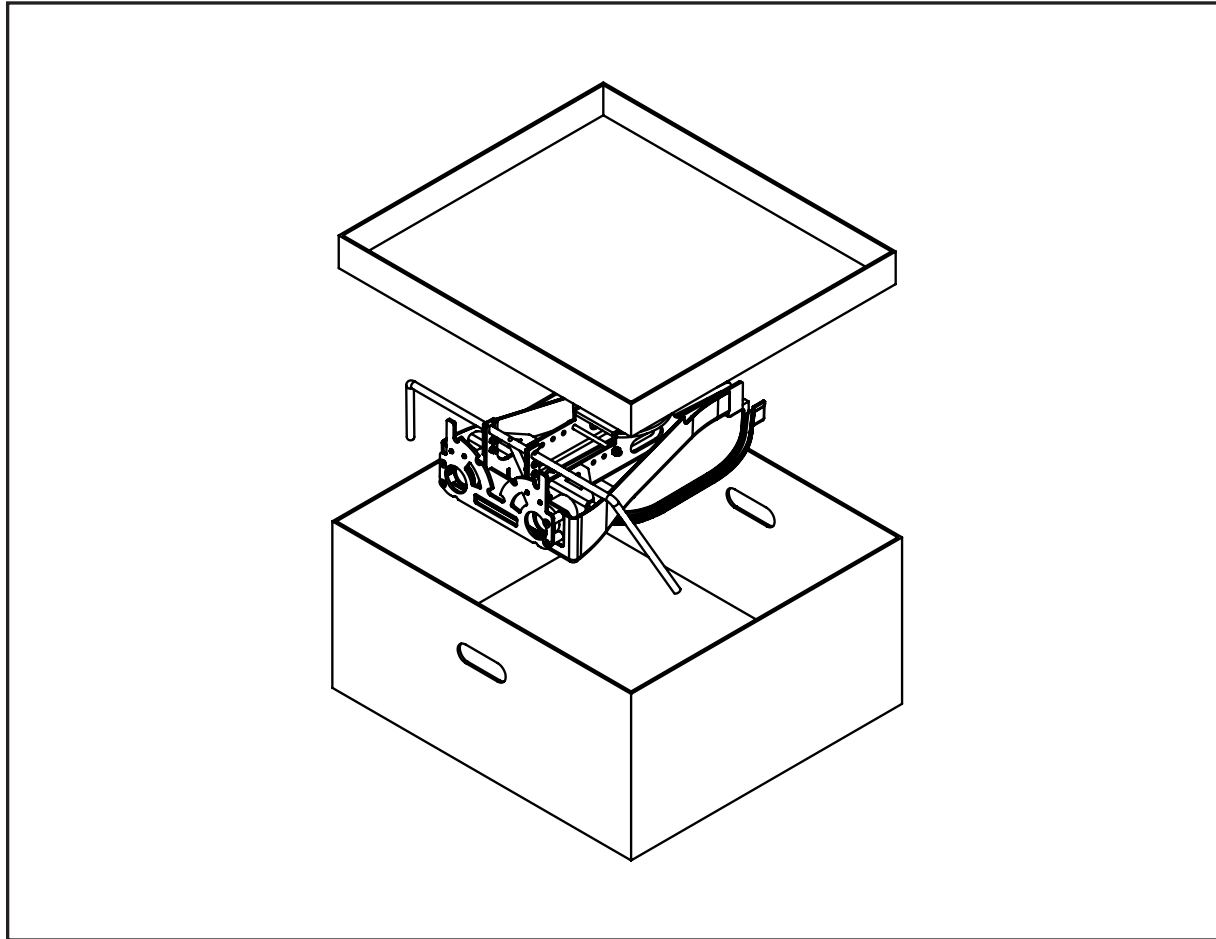

Remove the chassis leg from the box.

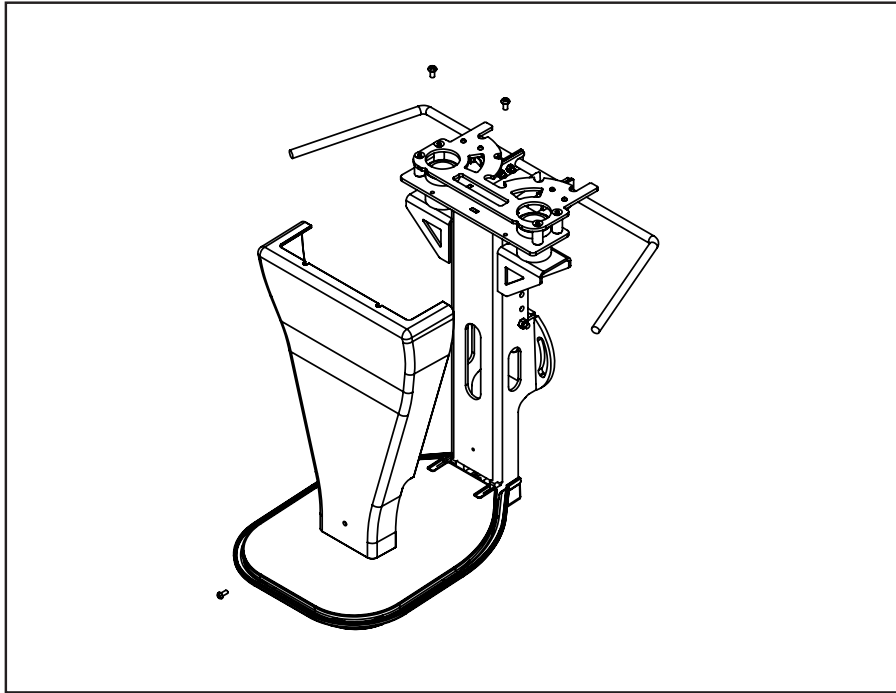

Remove the plastic cover by releasing the two top screws and removing the single lower screw. Place the plastic cover to one side.

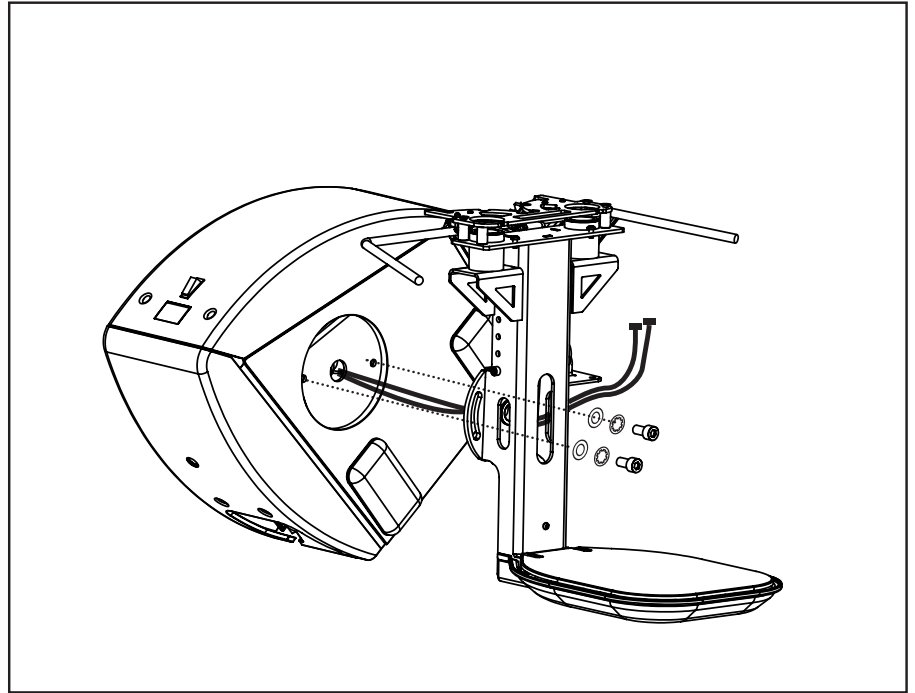

Place chassis leg directly onto the mounting point feeding the cable through the leg for the footrest and joystick connections, then loosely insert fixing bolts and washers.

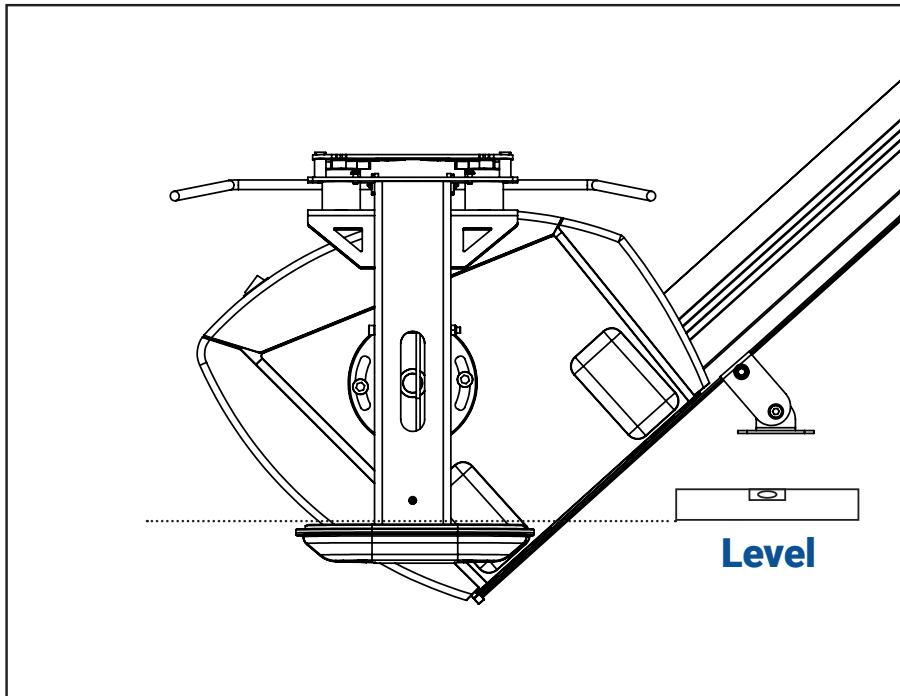

Before tightening, use a spirit level to set the footrest level to the angle of the rail and tighten the bolts.

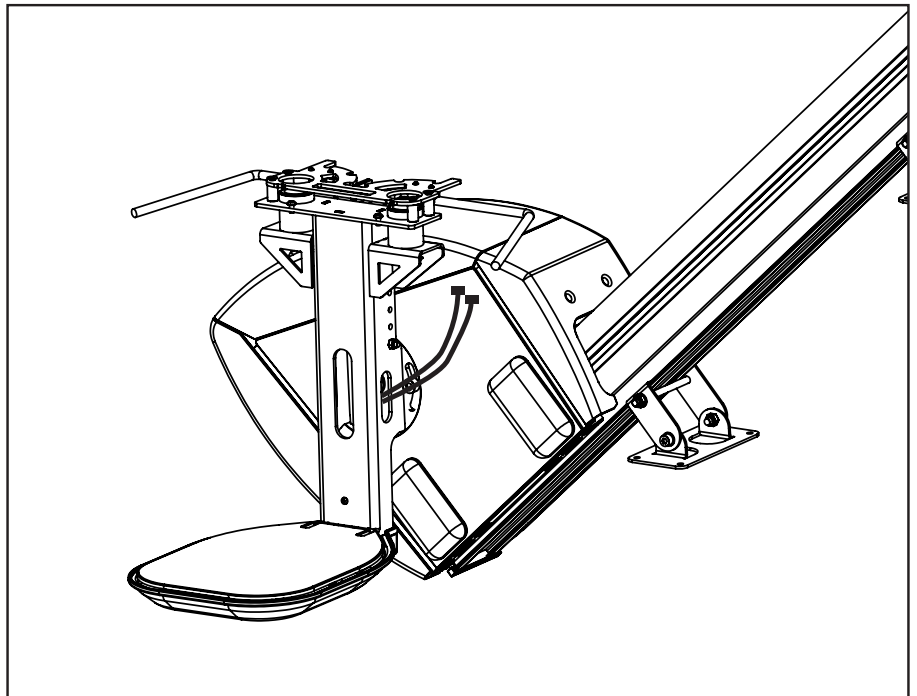

Ensure the cables are free and passed through the hole on the side of the chassis leg.

**▲ WARNING**

The fixing bolts must be tightened to 84Nm

# Seat Assembly

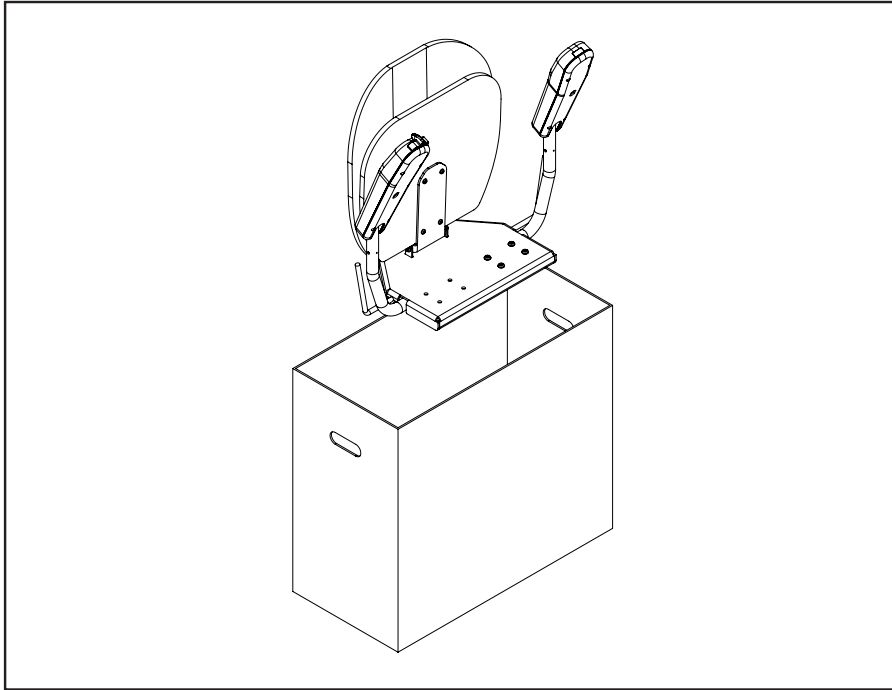

Unbox the seat assembly.

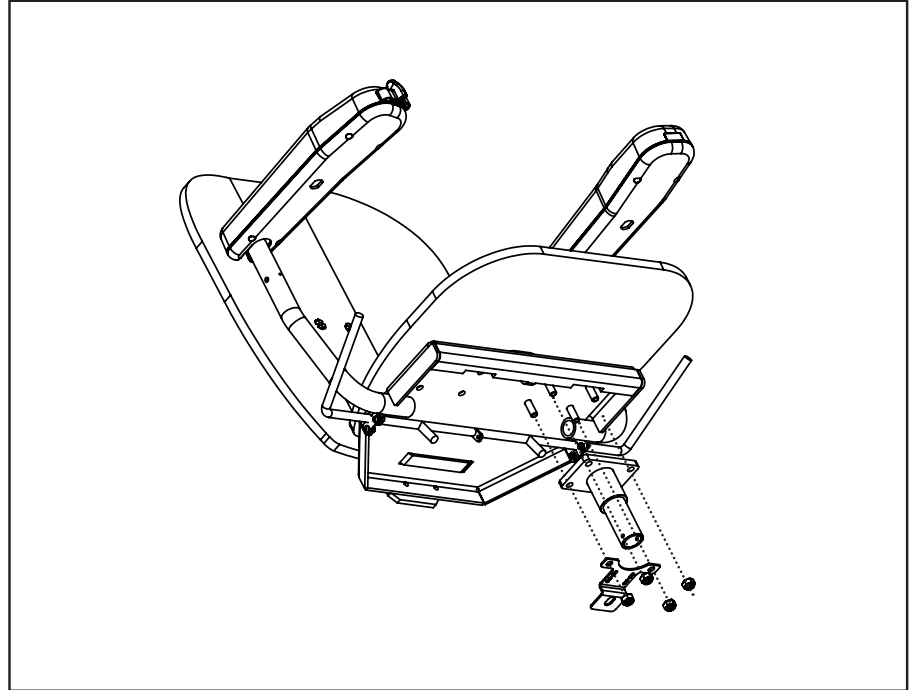

Fixing the boss to the seat. The boss should always be mounted on the upside of the seat.

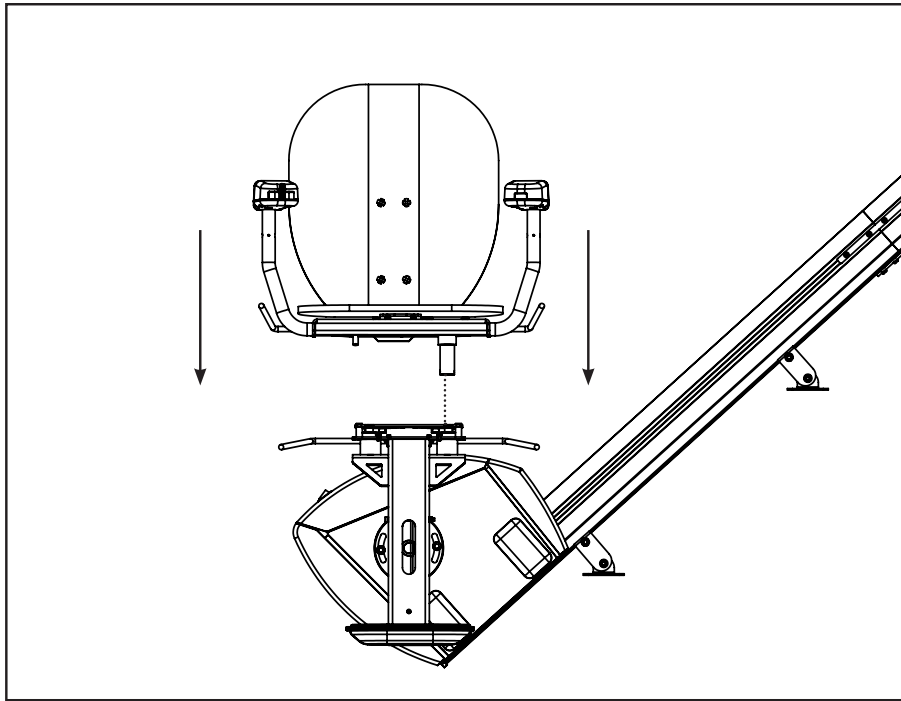

Unbox seat and lower swivel post into the chassis leg. Carefully making sure the cable is passed through the tube on the chassis leg and can move freely.

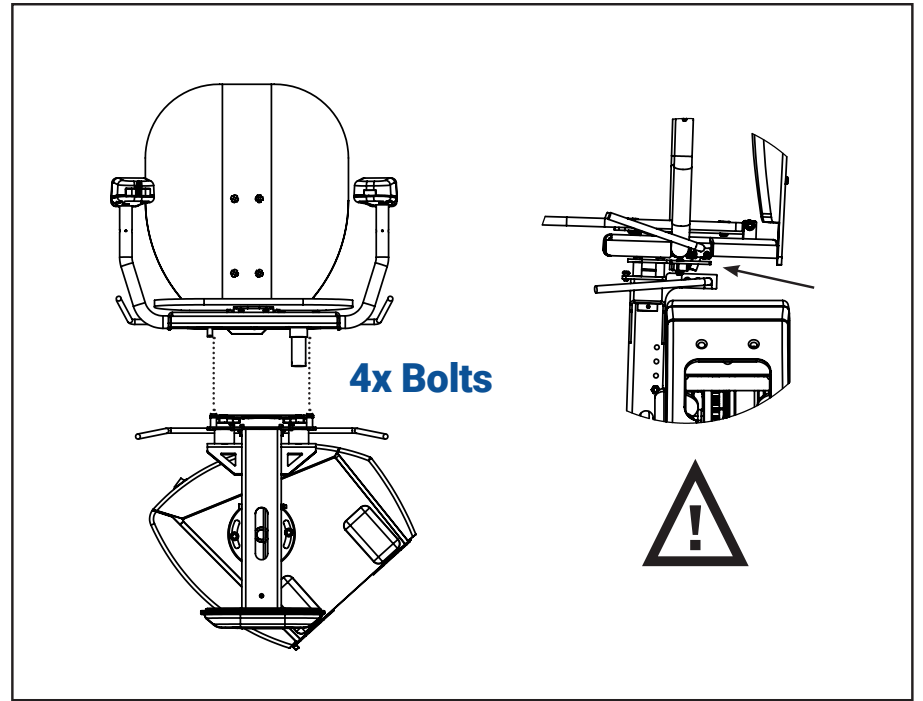

Ensure swivel bar locator sits in the correct slot, then bolt the seat top to the chassis leg with the 4 bolts provided.

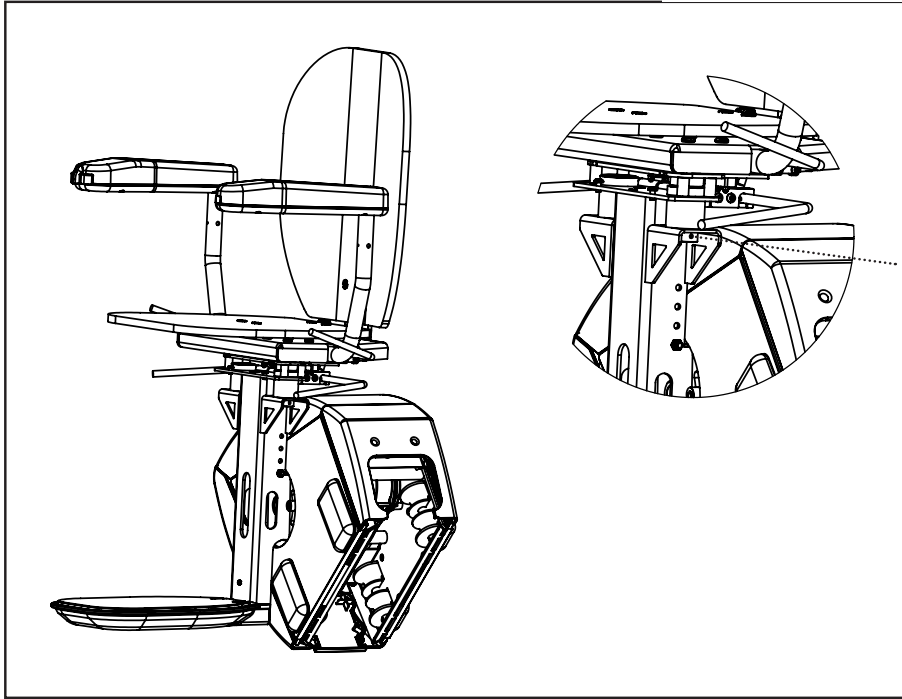

To ensure the seat cannot come loose from the chassis leg please insert the XX grub screw through the chassis leg into the seat post

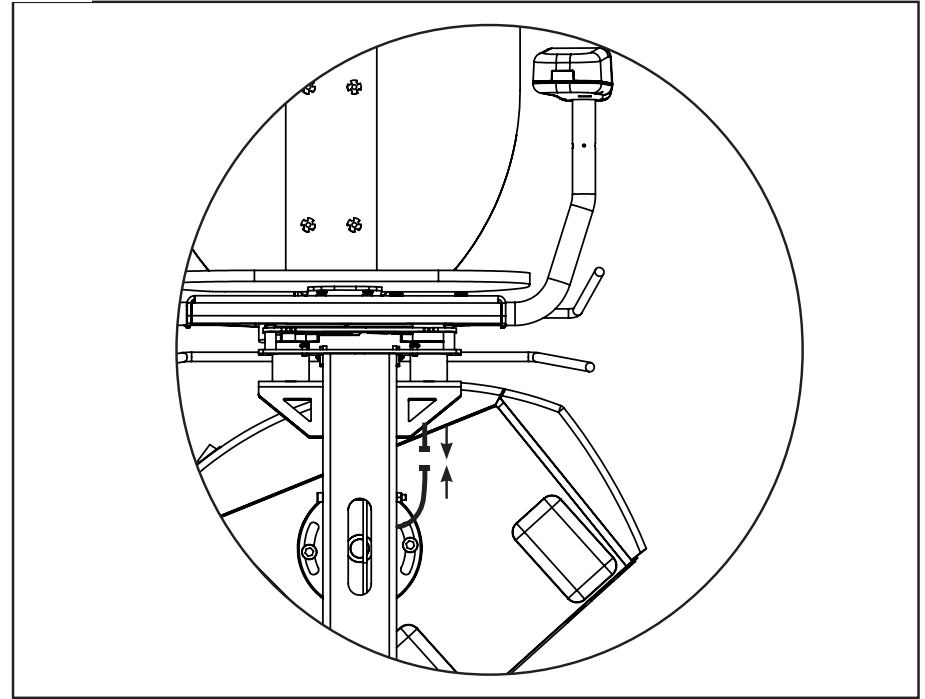

Connecting the joystick cable from the seat assembly to the drive unit. Be careful not to snag the two.

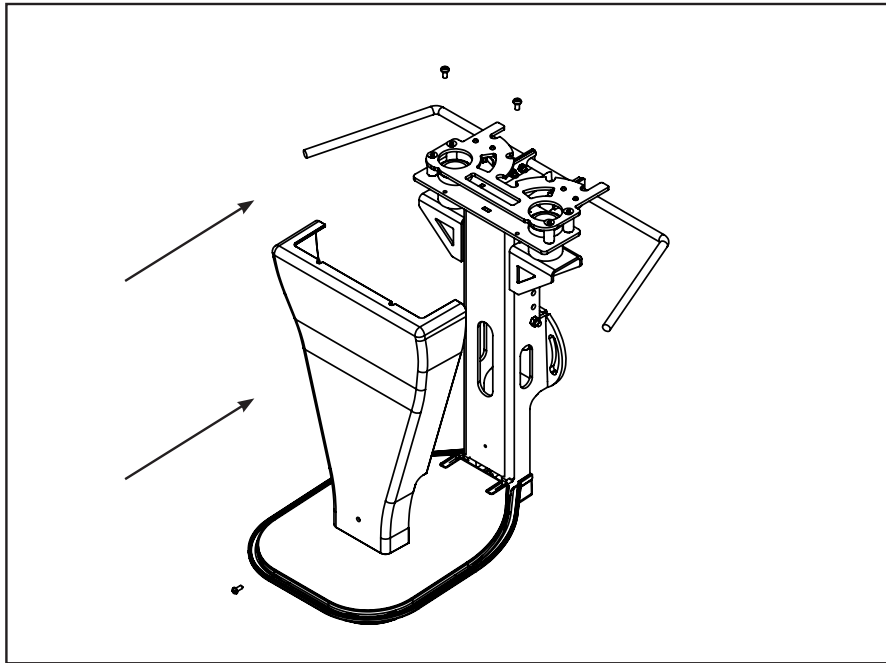

Replace the front plastic cover and tighten the 3 screw to secure.

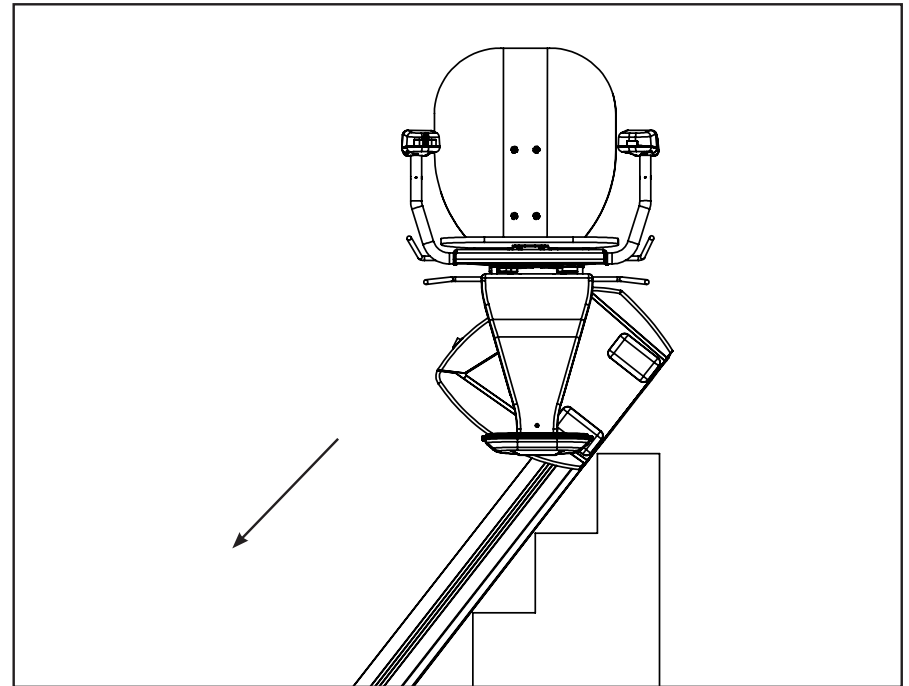

Turn on the lift and move down the rail so top charger can be installed.

# Remote Controls

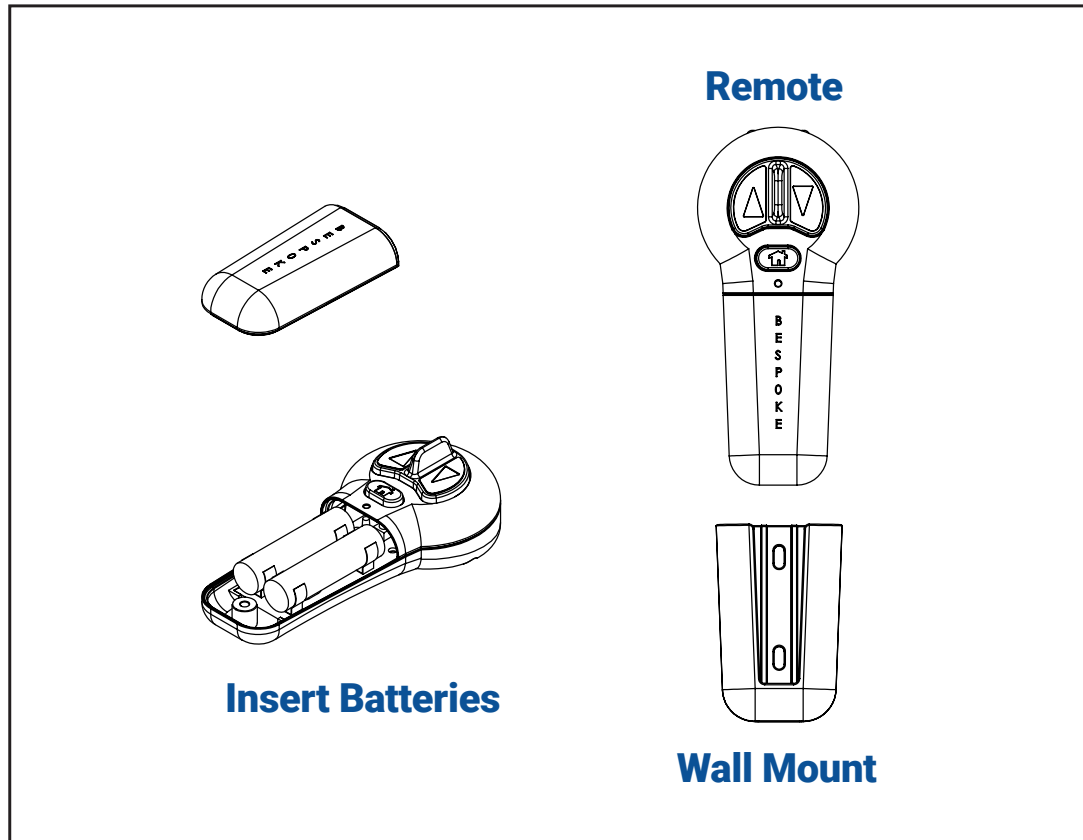

The remotes will already come pre-programmed to the lift, should you need to program them, turn the lift off/on again, then within the first 5 minutes of the lift being switched back on, press and hold the reset button (using a small blunt item such as a paper clip) on the remote control for 3 seconds then press any directional button and the remote will be paired.

Repeat the process again for any additional remote controls. The remotes will now be paired to this lift.

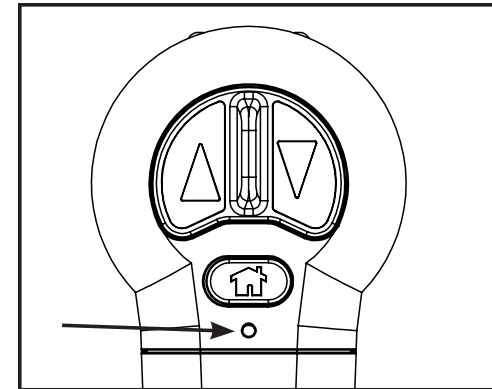

# Top Charge Point

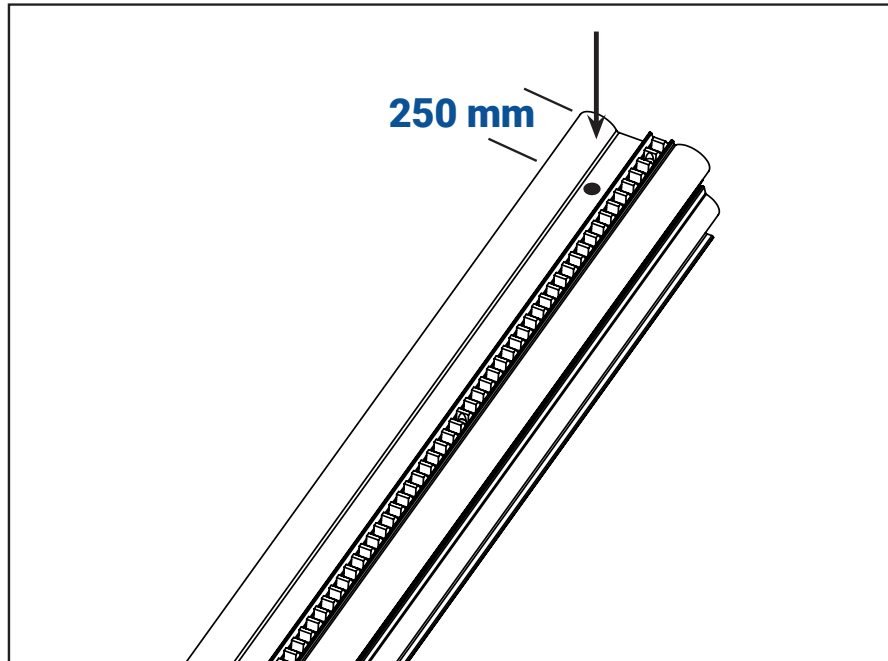

Fitting the final charge point.

Drill 10 mm hole 250mm from the top edge of the rail.

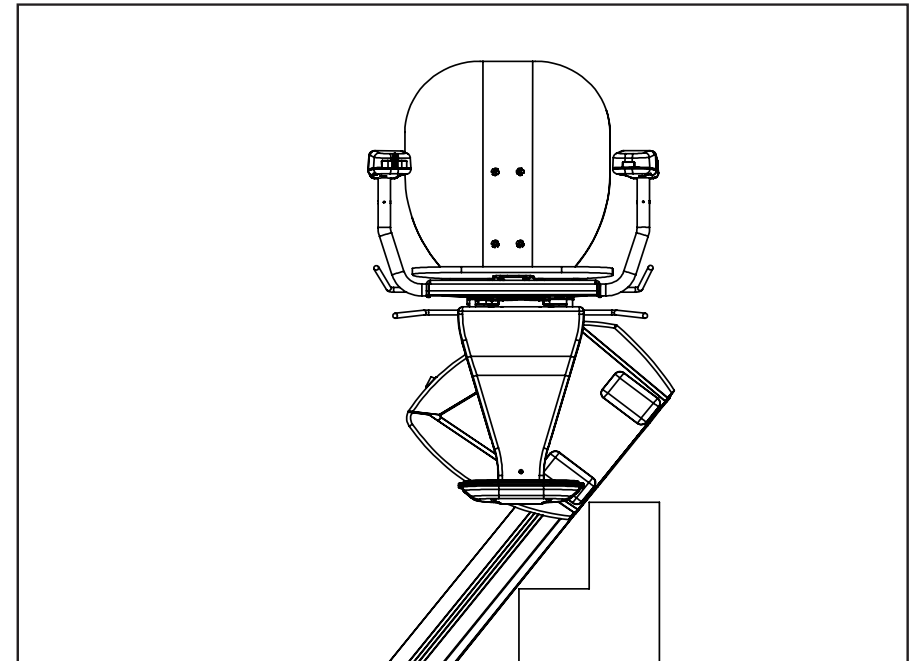

Drive the stair lift to the top of the stairs, stopping at the desired position.

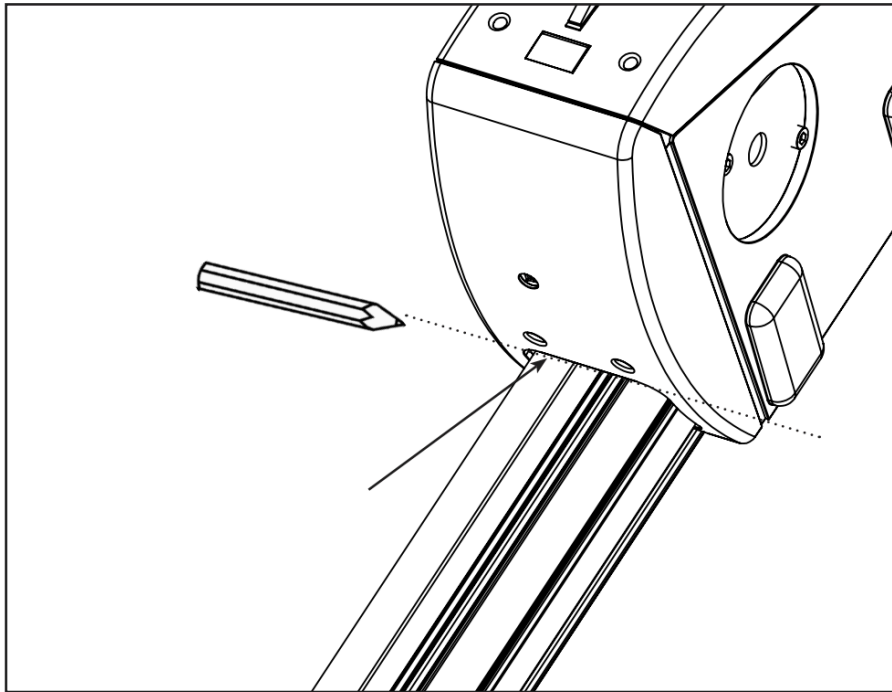

Once in the desired parking position, mark the rail on the where it becomes visible from the drive unit with a pencil.

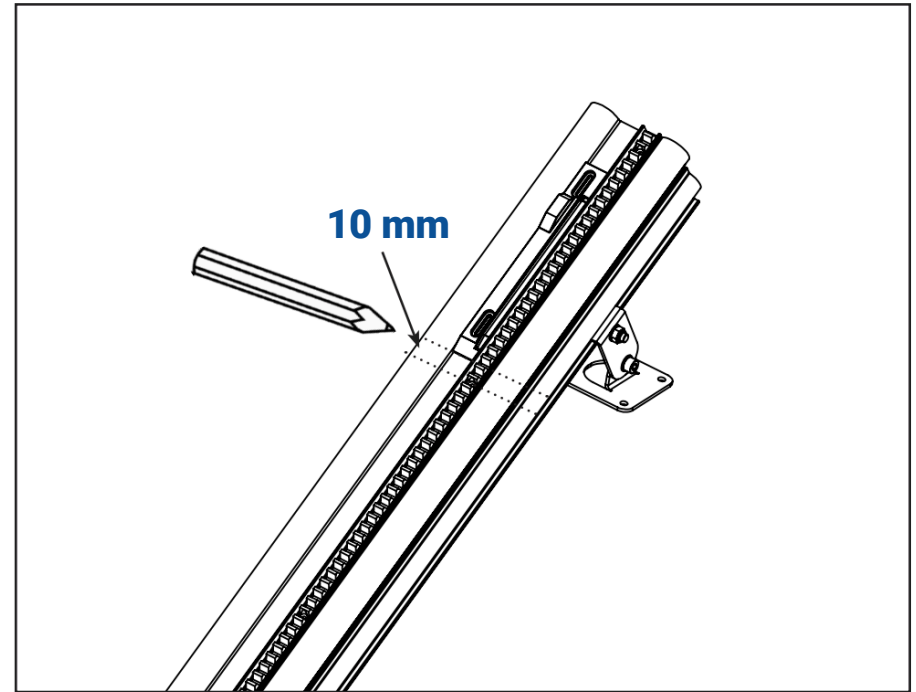

Measure upward 10mm from the original mark for the position of the lower edge of the top charge point

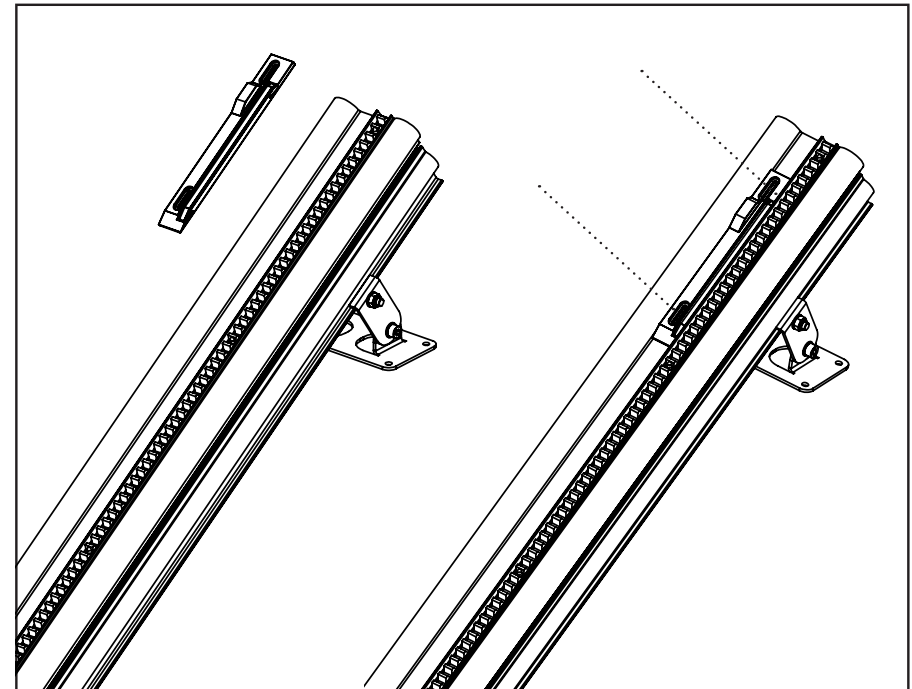
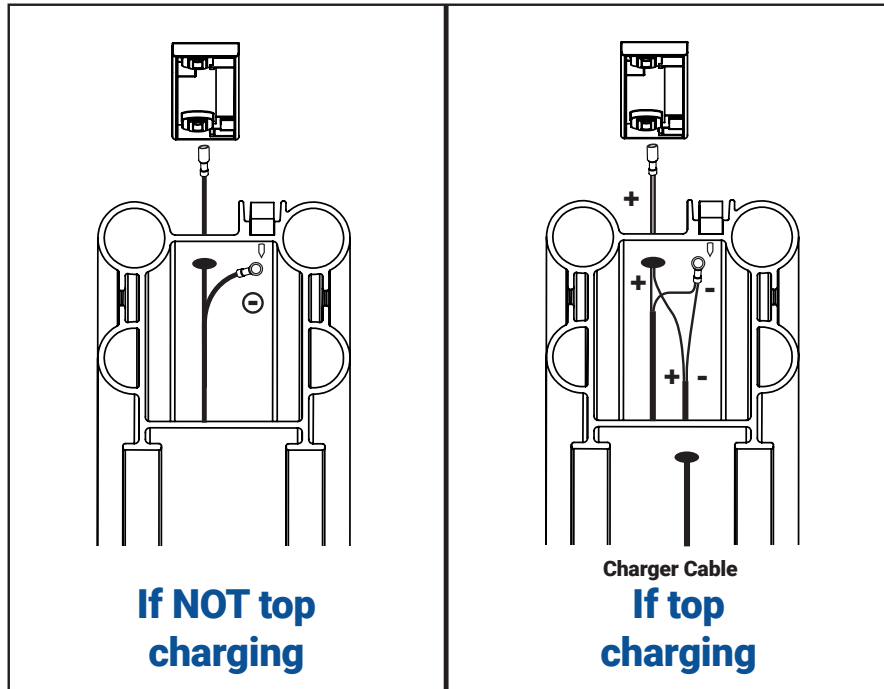

See diagrams above to illustrate the wiring methods for connecting top the charge point. Left image for wiring without the charge and right image with the charger at the top.

Fix with the self tapping screw ensuring the charge point is in the position marked on page 29.

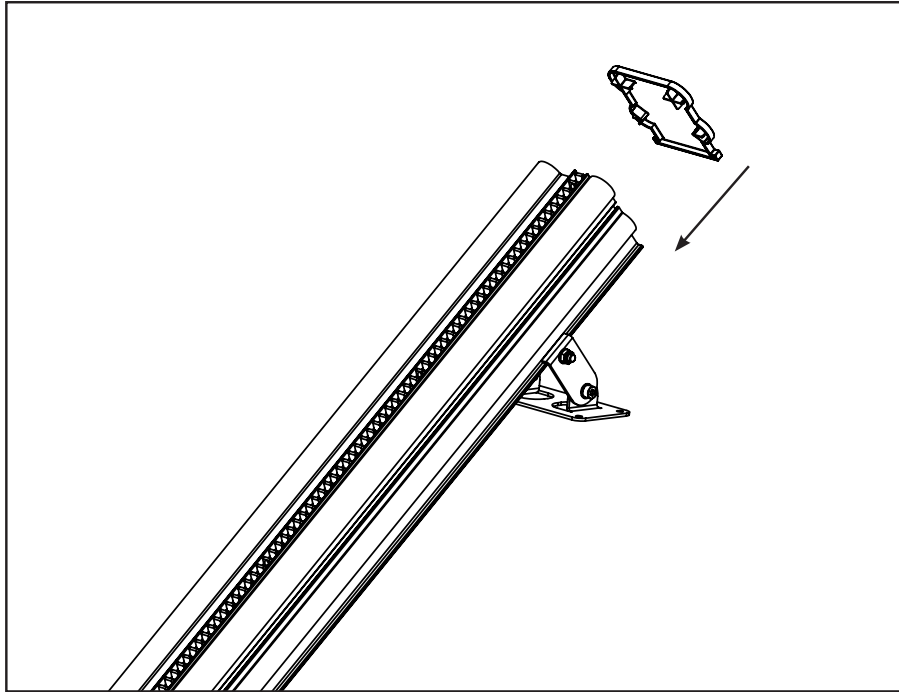

Once the cables are tucked back inside the rail you can now place the plastic end cap.

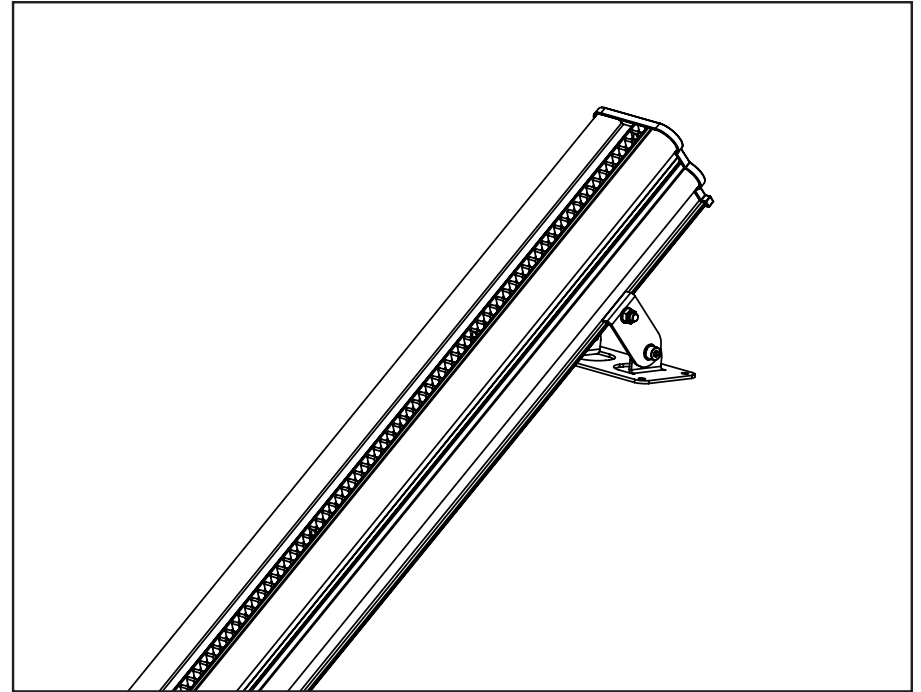

Place the upper cap onto the rail

# Troubleshooting

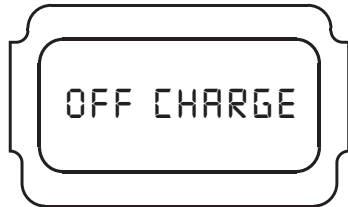

## Lift not Charging

- Check lift is parked on a charge point.
- Check the voltage at the charge point, the power is turned on and polarity is correct.



## Footrest Safety Switch Activated

- Check for obstructions and covers able to move freely.
- Check Footrest wiring loom for continuity as marked on the PCB and using the wiring diagram for correct switch cables.

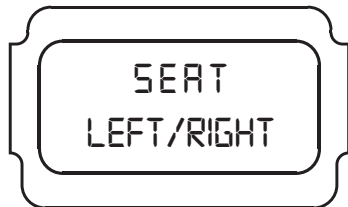

## Main Chassis Safety Switch Activated

- Check for obstructions and covers able to move freely.
- Check Mainframe wiring loom for continuity as marked on the PCB and using the wiring diagram for correct switch cables.

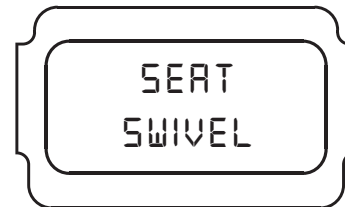

## Seat Swivel Safety Switch Activated (*will also show when powered swivel is in motion*)

- Check seat is in home position
- Check swivel switch is closed, located on the swivel boss under the seat.
- Check continuity on orange wire located in the mainframe loom.

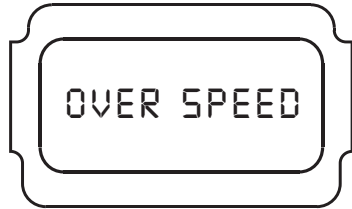

### **Over Speed Switch is Activated**

- Wind the lift upward using the handwinder.

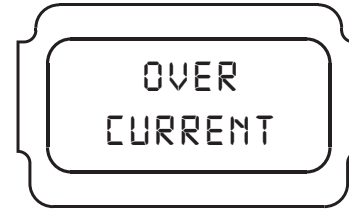

### **Lift is Drawing too Much Current**

- Check rack / pinion is clear for the lift to move.
- Check customer weight does not exceed limit.



### **Relay is Sticking on Main PCB**

- Gently tap the relay to free the mechanism, if this doesn't work, a new PCB will be required.

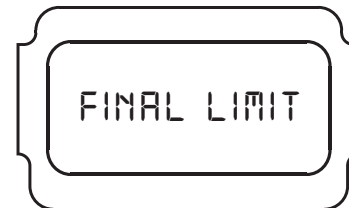

### **Lift has Over Traveled on Endstop**

- Wind the lift away from the endstop and try to operate the stair lift.

# Wiring Diagram

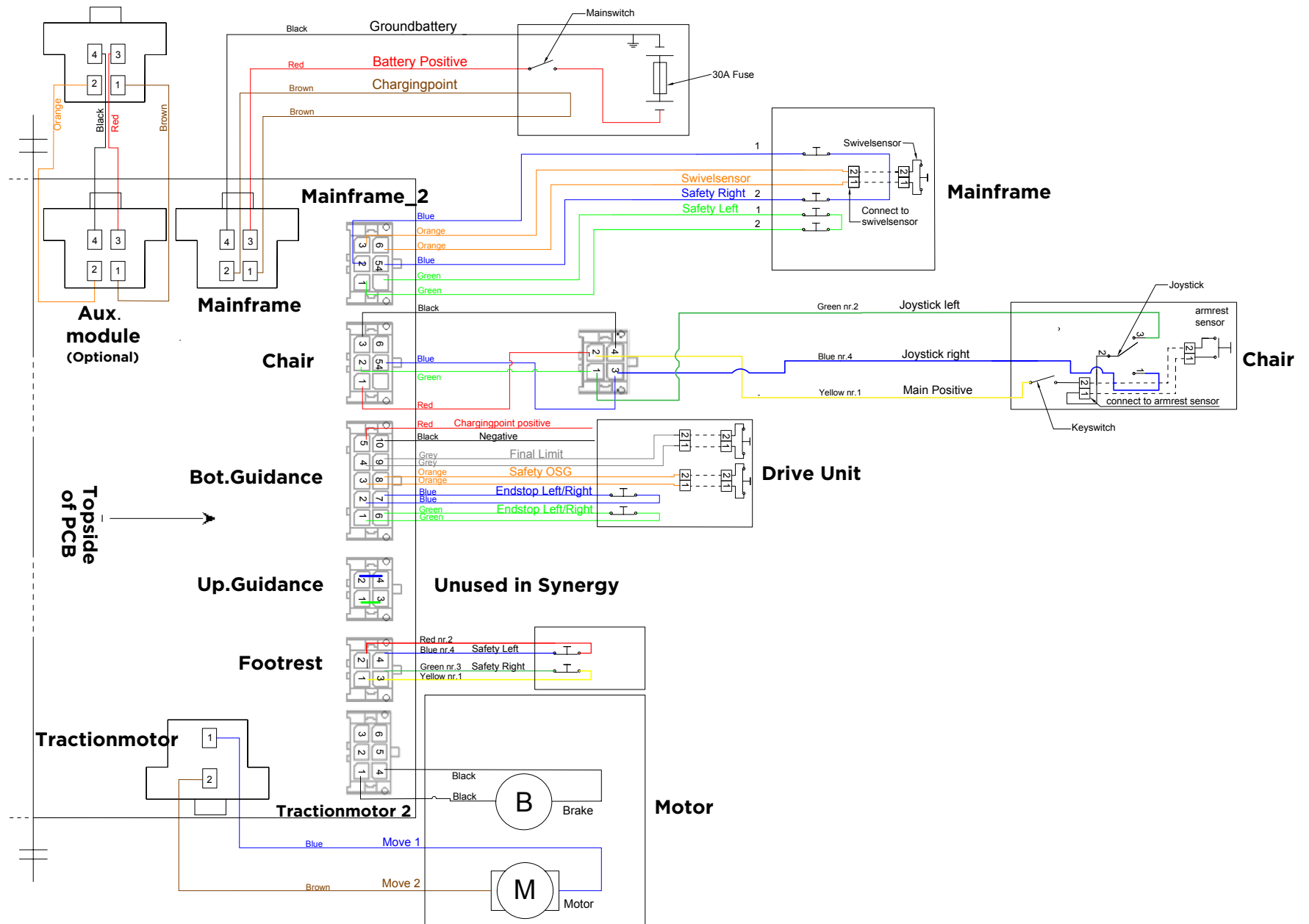

# Demonstration and Handover

**Demonstration**      **User Booklet**  
**Explanation**      **Paperwork Completion**  
**User Safety**

1. Ask user to stand clear of the stair lift making sure that they have a clear view of the lift.
2. Demonstrate the operation of the seat and footrest (manual or powered if fitted); advise the user to stand clear of the footrest to avoid the footrest coming into Contact with the users legs.
3. Explain the L.E.D. functions on the chair arm clearly.
4. Explain the operations and positions of all the on/off switches. Explain that the Key switch should always be turned off before getting in/out of the chair.
5. Explain the operation and position of the directional controls on the chair.
6. Explain that if constant pressure is released from directional controls the lift will stop, and there is approximately a three second delay before the stair lift will restart.
7. Explain the swivel function (manual or powered, if fitted) and also that the lift will stop automatically at the top and bottom of the rail. Explain manual override of a powered swivel if fitted. Demonstrate and explain the manual override function should only be used if a fault develops with the power functions, and when used, should only swivel in the up direction as a safety measure. On **NO** occasion should the manual override function allow the user to swivel the chair in the down direction.
8. Ask the user to sit comfortably on the seat and explain the use of the seatbelt (the seatbelt should always be used). Ensure the user does not extend their arm beyond the seat back.

9. Ask the user to operate the stair lift to the top of the stairs. Go up first so as not to block your own access.
10. Ensure that a swivel operation is carried out, and the customer alights from the lift. Ensure the user has turned off the chair Key switch.
11. Ask the user to complete a downward journey.
12. If the stair lift has a hinge, then this option will have to be fully explained at this point, all controls, interlocks, safety features, and general operation.
13. Once the user is clear on the operation of the lift show the operation and position of all safety edges.
14. Ensure that all of your instructions have been clearly understood.
15. Invite the user to sit down comfortably while you explain the user handbook. Ensure that the Service details are pointed out.
16. **Ask the user to read and sign the handover sheet and any other supporting documentation. Explain that the handover sheet is also a receipt for any payment collected.**



5110 Atlantic Ave. Raleigh, NC 27616  
[AmeriGlide.com](http://AmeriGlide.com)